

KW-FF1BB[Battery], FOR BULB FLATS

FILLET & BUTT WELDER FOR BULB FLATS, TOP DRIVING, ONE TORCH, STITCH-CONTINUOUS
BULB FLAT SIZE, 80-180mmH

APPEARANCE

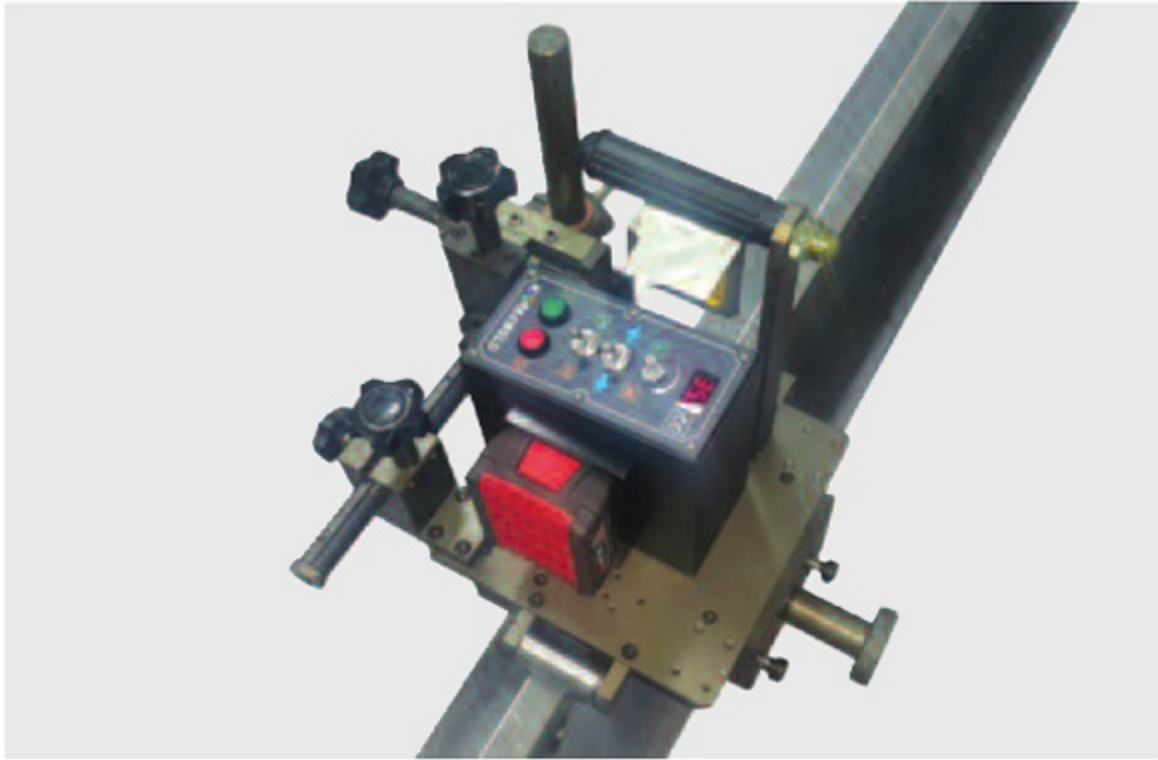

FEATURES

- Single torch, Applying Bulb Profile welding traveling on the top of the profile.
- X-Y slider helps setting torch widely
- Both mechanized & manual torches useful.
- Max pulling power 20kgf and Max. 30° climbable.
- Crater filling time at the beginning and ending of the welding can be controlled for 0~3 seconds.
- Travel speed in cm/min or inch/min programmable.
- Battery power, 18Vdc 4.0Ah lithium-ion, 10-12Hrs use

FILLET WELDING

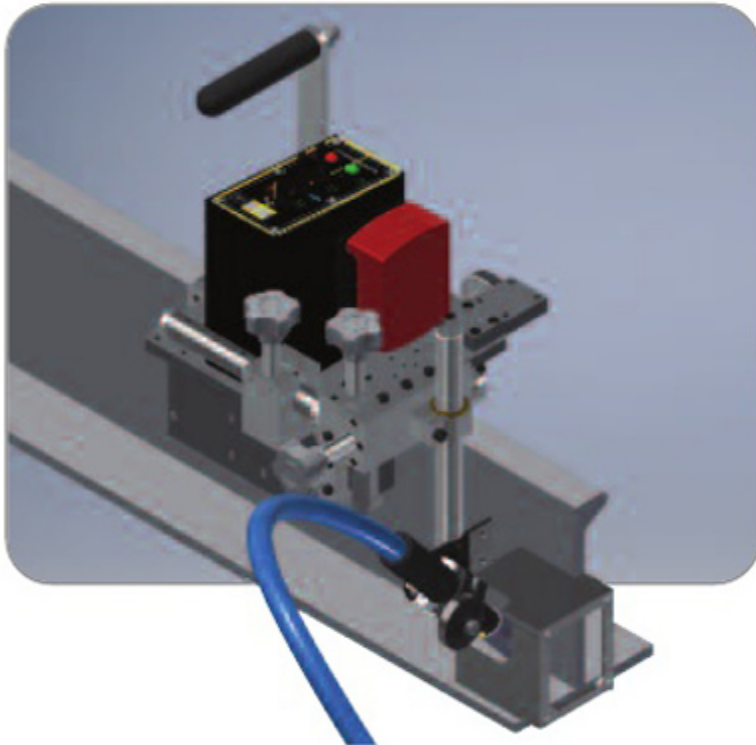

BUTT WELDING

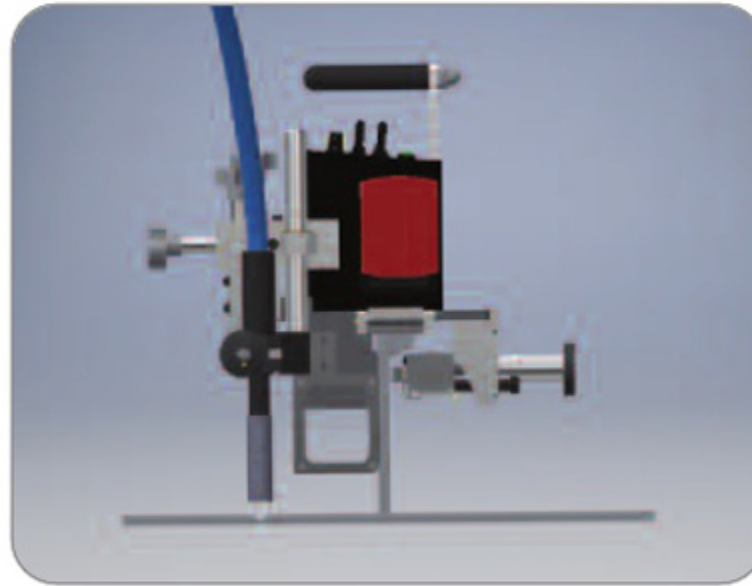

WORK PIECE

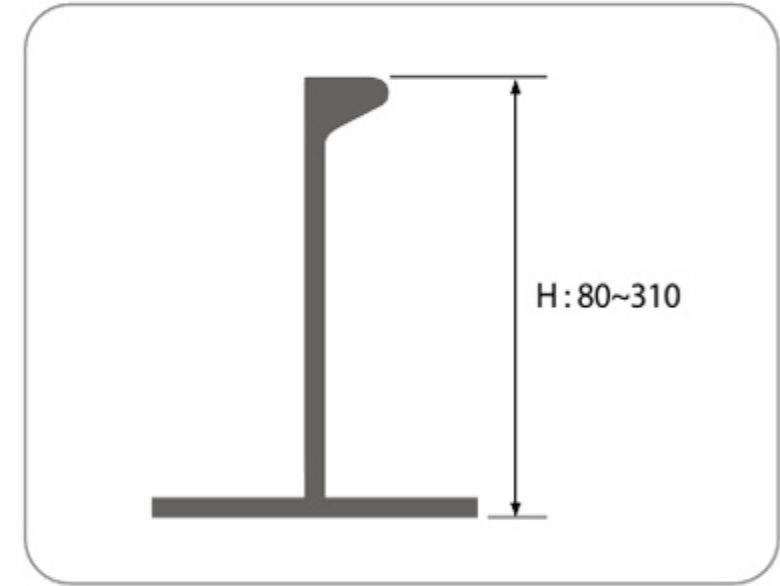

MAJOR PARTS	DESCRIPTIONS	SPECIFICATIONS
General	Size in mm(WHL), Weight	Carriage: 400 x 370 x 330, 9.0Kg
	Input Power	Lithium-ion Battery 18Vdc 4.0Ah 10-12Hrs use
Traveling Unit	Motor	24Vdc, 10W, 5,000rpm
	Reducer	1:624 (gear ratio 1:1)
	Speed	0~860mm/min
	Power transmission	4 wheels chain driven
	Magnet location	Bottom & side on the carriage
X-Y slide	X-slide stroke	0~50mm
	Y-slide stroke	0~50mm
	Rapid slide stroke	0~60mm