

GULLCO

WORLD LEADERS IN THE DESIGN,
MANUFACTURE & DISTRIBUTION OF AUTOMATED
WELDING SYSTEMS AND ACCESSORIES
CUT COSTS, IMPROVE QUALITY, AND INCREASE EFFICIENCY WITH THESE PROVEN
GULLCO PRODUCTS

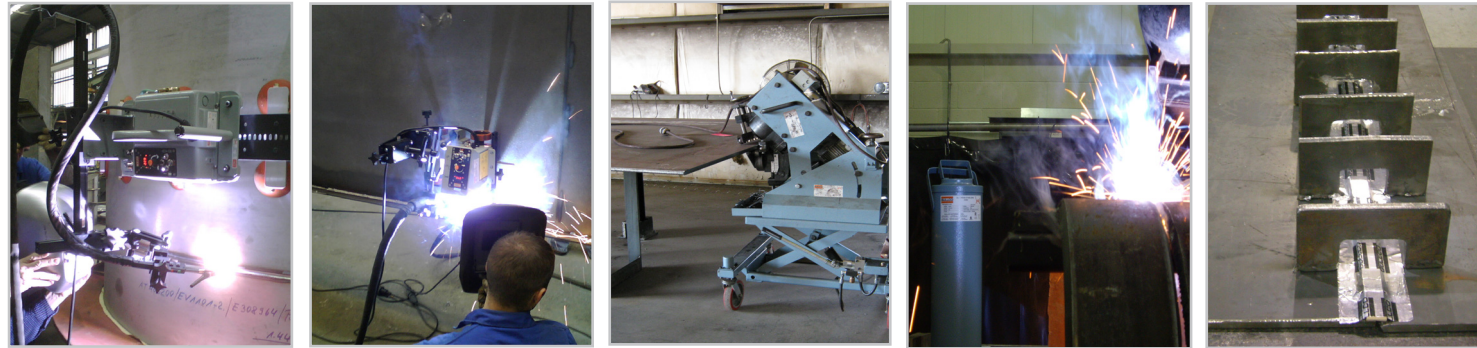

KAT®SYSTEMS	MOGGY®	WELDPREP	OVENS	CERAMICBACKING
<ul style="list-style-type: none"> Oscillators Torch indexers Flex & Rigid KAT® Programmable Travel Carriages Seam Trackers Bridge Units Circle Cutting System 	<ul style="list-style-type: none"> Trackless Fillet & Butt Welding, Stitch Welding control Radial Oscillation Control 6" V-groove Track Available 	<ul style="list-style-type: none"> Bevellers Positioners Grippers Kamel Pipe Turning Rolls 	<ul style="list-style-type: none"> Flux Rebake Flux Holding Flux Hoppers Electrode Stabilizing 	<ul style="list-style-type: none"> KATBAK® Ceramic Weld Backing Impart Uniform X-Ray Quality Back Beads Eliminate Costly Grinding & Re-welds Knuckle Joints for Use On Flat or Curved Surfaces

CONTACT GULLCO OR YOUR GULLCO DISTRIBUTOR TODAY FOR INFORMATION ON ANY OF THESE PRODUCTS

KAT, KBM, MOGGY, KATBAK & SAM are registered trademarks of Gullco Enterprises Limited

SPECIFICATIONS ARE SUBJECT TO CHANGE WITHOUT NOTICE, . ALL DIMENSIONS ARE NOMINAL

Distributed by:

GULLCO		
CANADA - GULLCO INTERNATIONAL LIMITED	Phone: 1-905-953-4140	Fax: 1-905-953-4138 e-mail: sales@gullco.com
U.S.A - GULLCO INTERNATIONAL INC.	Phone: 1-440-439-8333	Fax: 1-234 808-4146 e-mail: ussales@gullco.com
EUROPE - GULLCO INTERNATIONAL (U.K.) LIMITED	Phone: +44 1257-253579	Fax: +44 1257-254629 e-mail: uksales@gullco.com
AUSTRALIA - GULLCO INTERNATIONAL PTY LIMITED	Phone: 61 (0)7 3348 5515	Fax: 61 (0)7 3348 5510 e-mail: ausales@gullco.com
INDIA - GULLCO INTERNATIONAL INDIA PVT LIMITED	Phone: +91-20-2551-1433	Fax: +91-20-2551-1433 e-mail: indsales@gullco.com
CHINA - GULLCO INTERNATIONAL SHANGHAI LIMITED	Phone: +8621-50460341	Fax: +8621-50463554 e-mail: c.zhang@gullco.com
SINGAPORE - GULLCO INTERNATIONAL LIMITED	Phone: +65-9385-4468	e-mail: benny.lim@gullco.com
LATIN AMERICA - GULLCO INTERNATIONAL LIMITED	Phone: 55-11-99485-1336	e-mail: rogerio.macedo@gullco.com
GERMANY - ms gmbh Melchior Schweißtechnik	Phone: +49(0)173 5437722	Fax: +49(0)208 999 38-38 e-mail: christian.mertens@ms-gmbh.com

GULLCO.COM

KA-21-05

WELDING AND CUTTING AUTOMATION

GULLCO



WELDING AND CUTTING CARRIAGE ACCESSORIES - KAT®

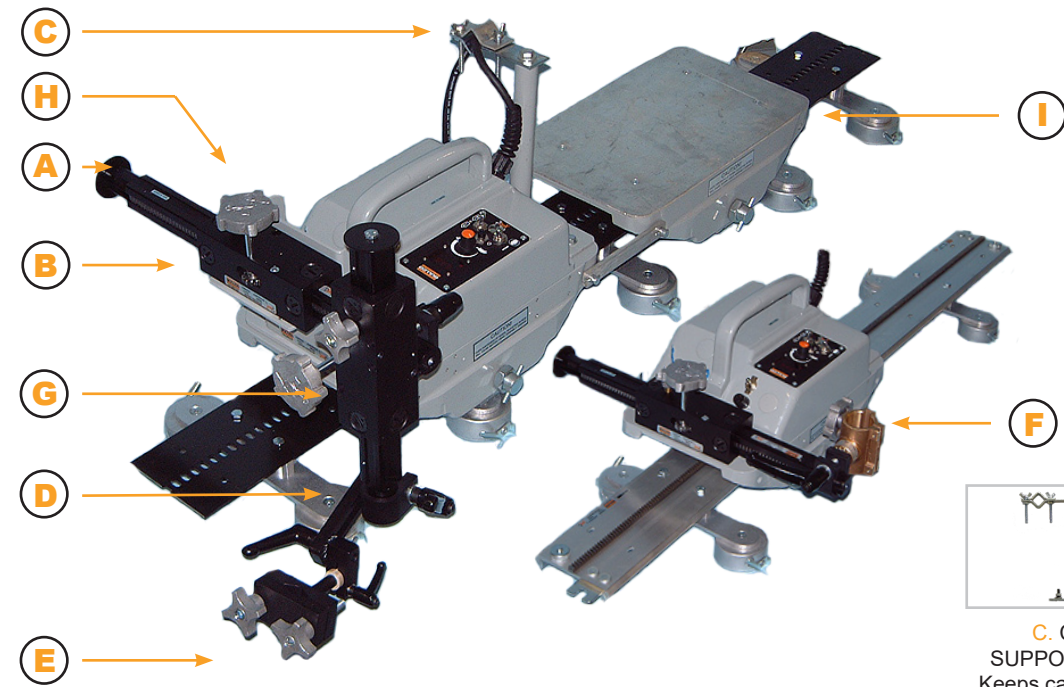

A. RACK ARM
Square with one end turned. Heavy duty & Extra heavy duty



B. RACK BOX
Available with standard or micro adjustment. Cross head & Arm Mount rack boxes also available

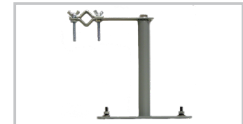

C. CABLE SUPPORT CLAMP
Keeps cables clear of work area



D. CLAMPS
Available as swivel or square.



E. SEMI-AUTOMATIC GUN HOLDERS
Suitable for most semi-automatic welding guns



F. BRONZE CUTTING TORCH HOLDERS
Accepts standard 1 3/8" (35 mm) cutting torch



G. 4 MOTION SEMI-AUTO GUN HOLDER
Mounts on the KAT® horizontal rack arm to provide 5" (127 mm) of vertical adjustment 360° torch rotation & two directional angle tilt



H. RISER BRACKET
To mount rack box higher than carriage when required



I. IDLER CARRIAGE
For conveying auxiliary welding and cutting equipment

GULLCO

GULLCO.COM

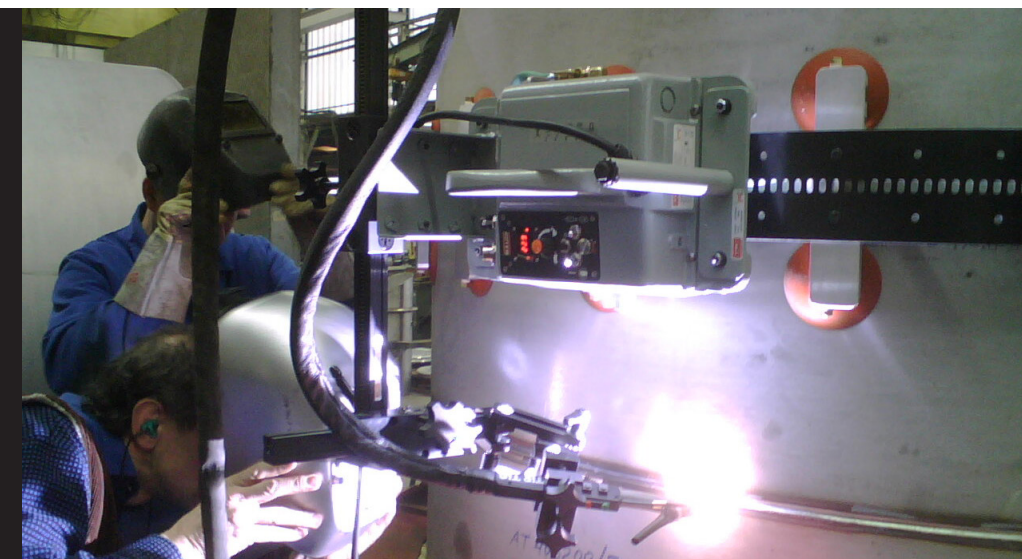

RACK BOXES

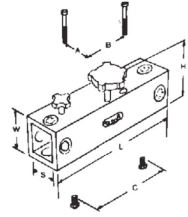

		H	W	L	S	A	B	C
HEAVY DUTY GK-171-650 GK-171-655*	In.	4.25	2.0625	6	1.125	1.625	2.625	-
	mm.	10.8	52.39	152.4	28.57	41.27	66.67	-
EXTRA HEAVY DUTY GK-190-650 GK-190-655*	In.	4.5	2.5	10	1.5	2	3.3	6
	mm.	114.3	63.5	254	38.1	50.8	83.82	152.4

***WITH MICRO FINE ADJUSTMENT GEAR BOX**

RACK BOXES FOR ARM MOUNTING

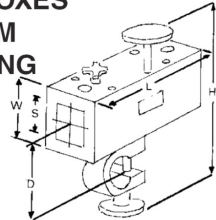

		H	W	L	S	D
HEAVY DUTY GK-171-685 GK-171-690*	In.	7	2.0625	6	1.125	1.75
	mm.	177.8	52.39	152.4	28.57	44.45
EXTRA HEAVY DUTY GK-190-685 GK-190-690*	In.	7.5	2.5	10	1.5	2.25
	mm.	190.5	63.5	254	38.1	57.15

***WITH MICRO FINE ADJUSTMENT GEAR BOX**

RACK ARMS



HEAVY DUTY RACK ARMS

1 1/8" (29mm) square rack arm and rack with one end turned to 1 1/8" (29mm) diameter

- GK-171-047-1 12" (305mm) long
 - GK-171-047-2 18" (457mm) long
 - GK-171-047-3 24" (610mm) long
 - GK-171-047-4 36" (914mm) long
- other lengths available on request

EXTRA HEAVY DUTY RACK ARMS

1 1/2" (38mm) square rack arm and rack with one end turned to 1 1/8" (29mm) diameter

- GK-190-047-2 18" (457mm) long
 - GK-190-047-3 24" (610mm) long
 - GK-190-047-4 36" (914mm) long
- other lengths available on request

CLAMPS

Swivel Clamps

for mounting torch holders, rack boxes and other KAT® accessories

		Dia.	W	D	A
HEAVY DUTY GK-166-183	In.	1.125	1.625	1.25	.775
	mm.	28.57	41.27	31.75	19.68

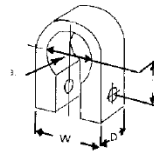

Square Clamps

for mounting welding guns, cutting torches and other KAT® accessories

		Dia.	W	D	A
HEAVY DUTY GK-166-236	In.	1.125	1.625	1.125	1.0625
	mm.	28.57	41.27	28.57	27
EXTRA HEAVY DUTY GK-190-236	In.	1.5	2.125	1.25	1.437
	mm.	38	54	31.75	36.5

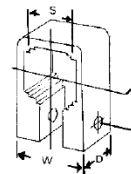

RACKBOX RISER BRACKET

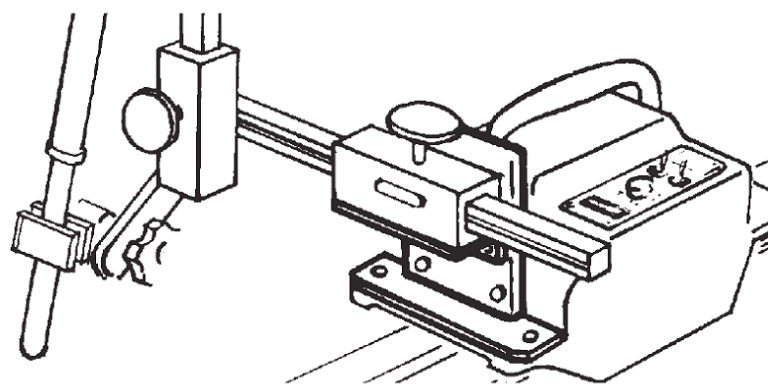

MODEL GK-190-066

For applications that require a mounting surface higher than the level provided with the rack box mounted directly on the front of the KAT® Carriage. Height can be increased by 2, 4 or 6" (51, 102 or 152 mm).

TORCH HOLDERS AND ASSEMBLIES

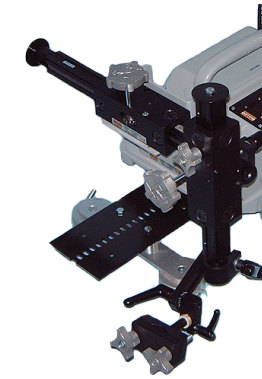

SEMI-AUTOMATIC 4 MOTION WELDING GUN HOLDER

MODEL GK-165-074-2

(complete unit)... For mounting on the KAT® horizontal rack arm to provide 5" (127 mm) of vertical adjustment, 360° torch rotation and two directional tilt. Supplied complete with standard 1 1/8" (29 mm) I.D. swivel clamp* and insulated linkage for the gun holder which is suitable for most semi-automatic welding guns. Gun holder jaws are adjustable from 5/8" (16 mm) to 1 1/2" (38 mm) *Note: can be supplied with 1 1/8" (29 mm) or 1 1/2" (38 mm) square clamp.

SEMI-AUTOMATIC GUN HOLDER



MODEL GK-165-145 (complete unit)... Complete with standard 1 1/8" (29 mm) I.D. swivel clamp* and insulated linkage for the gun holder which is suitable for most semi-automatic welding guns. Gun holder jaws are adjustable from 5/8" (16 mm) to 1 1/2" (38 mm) *Note: can be supplied with 1 1/8" (29 mm) or 1 1/2" (38 mm) square clamp

IDLER CARRIAGES

GK-171-154

Provides an 8 3/4" x 14 7/8" platform on which a variety of welding/cutting equipment can be mounted and towed individually or in tandem along straight or formed sections of KAT® Track by the Gullco KAT® Travel Carriage. Self aligning retractable wheels enable easy mounting at any point along the track. Load capacity is 100lbs.



REMOTE CONTROL PENDANT

Supplied with 8 ft. (244 cm) cable providing control of numerous KAT® functions.



STANDARD CUTTING TORCH HOLDERS

GK-165-068

Accepts standard 1 3/8" (35 mm) cutting torches with 32 pitch rack. Supplied with calibrated angle of tilt scale and 1 1/8" (29 mm) or 1 1/2" (38 mm) square clamp.



GK-165-068-M Accepts 1.280" (32.50mm) cutting torches. Supplied with calibrated angle of title scale as above.

CABLE SUPPORT CLAMP

GK-181-027

Swivel clamp assembly is readily mounted on the front or back of the KAT® Travel Carriage to keep cables clear of the work area. Clamp can be adusted to provide approximately 1 3/4" diameter holding opening



SEAM TRACKER SYSTEM

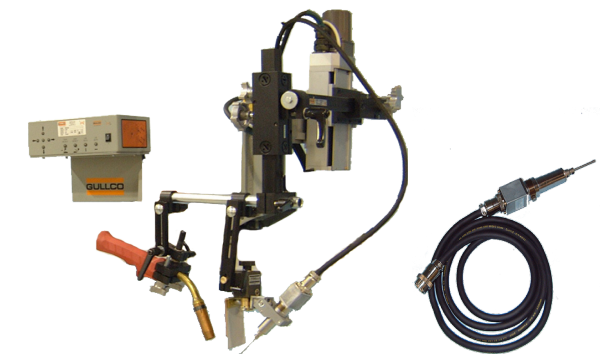

...high precision tracking system that maintain the torch in optimum operating position regardless of variations in the weld seam...providing improved quality and efficiency in a wide variety of welding operations.