

PIPE WELDING TURNING ROLLS - KAMEL ROLLS



Reduce pipe preparation costs with these portable automated turning rolls which rotates pipe from 2" to 16" (51- 406 mm) diameter. Two models are available; Model **KR-200-L** has a turning capacity of 1500 lbs (680 kg), and an infinitely variable forward/reverse speed range of 1-35.4 IPM (2.5-89.9 cm/min). Model **KR-200-M** has a turning capacity of 1500 lbs (680 kg) and an infinitely variable forward/reverse speed range of 2.2-70.8 IPM (5.6-180 cm/min). Rotation speed can be precisely controlled and displayed in inches/mm per minute on an optional LED control. Contact Gullco or your Gullco distributor for complete details on these highly efficient, cost effective turning rolls.

Electronic controls are resistant to damage from high frequency and electromagnetic interference.

Portable: total weight of power and idler roll is 69 lbs. (31.3 kg). Use anywhere that 42, 115 or 220-240 volts 50/60 cycle single phase power supply is available.

Long life, 6" (15.24 cm) diameter roller bearing wheels with rubber tires provide friction drive and uniformly smooth pipe rotation.

Protected on/off foot switch on 7.5 ft (2.3 m) cable provides maximum convenience and freedom for



Great For In-shop Pipe Manufacturing Applications

AUTOMATION PIPE TURNING ROLLS WITH FOOTSWITCH: KR-200-L AND KR-200-M



GULLCO.COM



SPECIFICATIONS

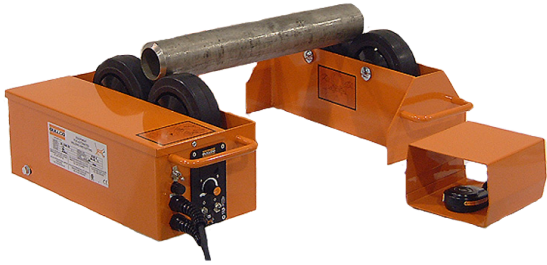

	POWER ROLLS	
	Model KR-200-L	Model KR-200-M
TURNING CAPACITY	1500 lbs (680 kg)	1500 lbs (680 kg)
LOAD CAPACITY/ROLL	750 lbs (340 kg)	750 lbs (340 kg)
PIPE DIA. RANGE	2"-16" (51-406 mm)	2"-16" (51-406 mm)
SPEED RANGE	1-35.4 IPM (2.5-89.9 cm/min)	2.2-70.8 IPM (5.6-180 cm/min)
WEIGHT	48 lbs (21.8 kg)	48 lbs (21.8 kg)
	IDLER ROLLS Model KR-750	
LOAD CAPACITY	750 lbs (340 kg)	
PIPE DIA. RANGE	2"-16" (51-406 mm)	
WEIGHT	21 lbs (9.5 kg)	

DIMENSIONS: POWER AND IDLER ROLLS

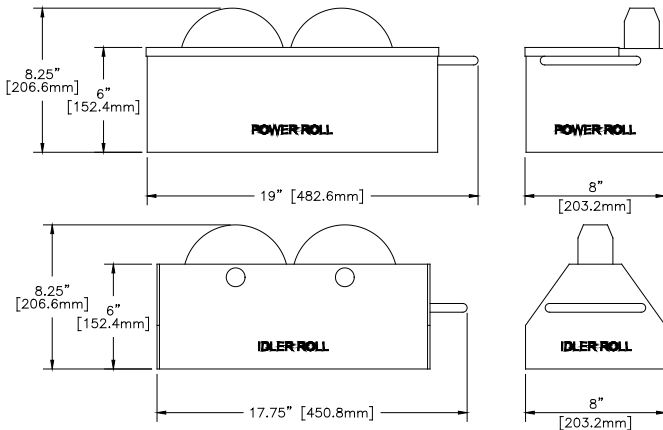

KAT, KBM, MOGGY, KATBAK & SAM are registered trademarks of Gullco Enterprises Limited

Distributed by:

GULLCO.COM

KR071223

FREE STANDING TORCH SUPPORTS AND TORCH / GUN HOLDERS

MODEL KR-1000 CSB TORCH SUPPORT 1 1/8" (28.6mm) square rack arms providing 22" (559 mm) of vertical adjustment and 10 1/2" (266.7 mm) of horizontal adjustment.

MODEL KR-2000 CSB TORCH SUPPORT Same as above but 1 1/2" (38.1mm) square rack arms providing 18" (457 mm) vertical adjustment and 6.5" (165 mm) of horizontal adjustment. Supplied with swivel mounted standard rack-type cutting torch holder.

Weight: 42 lbs (19.05 kg)

MODEL KR-1000 WSB TORCH SUPPORT 1 1/8" (28.6 mm) square rack arm providing 22" (559mm) of vertical adjustment and 10 1/2" (266.7mm) of horizontal adjustment. Weight: 25 lbs. (11.34kg)

MODEL KR-2000 WSB TORCH SUPPORT Same as above but 1 1/2" (38.1mm) square rack arms providing 18" (457 mm) vertical adjustment and 6.5" (165 mm) of horizontal adjustment. Supplied with insulated 4 motion, semi-automatic gun holder and swivel arm that allows adjustment of gun angle tilt.

Weight: 42 lbs. (19.05 kg)

NOTE:

The above models can be, and often are, supplied with the Gullco Motorized Rack Arm, equipped with a remote joystick control. See www.gullco.com for more information.



GULLCO



SPECIFICATIONS ARE SUBJECT TO CHANGE WITHOUT NOTICE

GULLCO

CANADA - GULLCO INTERNATIONAL LIMITED

Phone: 1-905-953-4140 Fax: 1-905-953-4138 e-mail: sales@gullco.com

U.S.A - GULLCO INTERNATIONAL INC.

Phone: 1-440-439-8333 Fax: 1-234 808-4146 e-mail: ussales@gullco.com

EUROPE - GULLCO INTERNATIONAL (U.K.) LIMITED

Phone: +44 1257-253579 Fax: +44 1257-254629 e-mail: uksales@gullco.com

AUSTRALIA - GULLCO INTERNATIONAL PTY LIMITED

Phone: 61 (0)7 3348 5515 Fax: 61 (0)7 3348 5510 e-mail: ausales@gullco.com

INDIA - GULLCO INTERNATIONAL INDIA PVT LIMITED

Phone: +91-20-2551-1433 Fax: +91-20-2551-1433 e-mail: indsales@gullco.com

CHINA - GULLCO INTERNATIONAL SHANGHAI LIMITED

Phone: +8621-50460341 Fax: +8621-50463554 e-mail: c.zhang@gullco.com

SINGAPORE - GULLCO INTERNATIONAL LIMITED

Phone: +65-9385-4468 e-mail: benny.lim@gullco.com

LATIN AMERICA - GULLCO INTERNATIONAL LIMITED

Phone: 55-11-99485-1336 e-mail: rogerio.macedo@gullco.com

GERMANY - ms gmbh Melchior Schweißtechnik

Phone: +49(0)173 5437722 Fax: +49(0)208 999 38-38 e-mail: christian.mertens@ms-gmbh.com