

1. Guarantee, liability for defects

1.1 The guarantee period is 12 months, or 6 months in case of a multi-shift system. It starts when the supplies leave the works. If dispatch is delayed due to reasons beyond supplier's control, the guarantee period shall end not later than 18 months after supplier's notification that the supplies are ready for dispatch. For replaced or repaired parts the guarantee period starts anew and lasts 6 months after replacement or completion of the repair, but not longer than the expiry of a period being double to the guarantee period stipulated in the preceding paragraph. The guarantee expires prematurely if the customer or a third party undertakes inappropriate modifications or repairs or if the customer, in case of a defect, does not immediately take all appropriate steps to mitigate the damage and give the supplier the possibility of remedying such defect.

1.2 Upon written request of the customer, the supplier undertakes at its choice to repair or replace as quickly as possible any parts of the supplies which, before the expiry of the guarantee period, are proved to be defective due to bad material, faulty design or poor workmanship. Replaced parts shall become the supplier's property if he does not renounce explicitly.

1.3 Express warranties are only those which have been expressly specified as such in the order acknowledgment or in the specifications. An express warranty is valid until the expiry of the guarantee period at the latest. If the express warranties are not or only partially achieved, the customer may first of all require the supplier to carry out the improvements immediately. The customer shall give the supplier the necessary time and possibility of doing so. If such improvements fail completely or in part, the customer may claim a reasonable reduction of price. If, however, the defects are of such importance that they cannot be remedied within a reasonable time and provided the supplies and services cannot be used for their specified purpose, or if such use is considerably impaired, then the customer shall be entitled to refuse acceptance of the defective part or, if partial acceptance is economically not justified for it, to terminate the contract. In such case the supplier can only be held liable for reimbursing the sums which have been paid to it for the parts affected by the termination.

1.4 Excluded from supplier's guarantee and liability for defects are all deficiencies which cannot be proved to have their origin in bad material, faulty design or poor workmanship, e.g. those resulting from normal wear, improper maintenance, failure to observe the operating instructions, excessive loading, use of any unsuitable material, influence of chemical or electrolytic action, building or erection work not undertaken by the supplier, or resulting from other reasons beyond supplier's control.

1.5 With respect to any defective material, design or workmanship as well as to any failure to fulfill express warranties, the customer shall not be entitled to any rights and claims other than those expressly stipulated in Clauses 1.1 to 1.4.

2. Exclusion of further liability on the supplier's part

All cases of breach of contract and the relevant consequences as well as all rights and claims on the part of the customer, irrespective on what ground they are based, are exhaustively covered by these general conditions of supply. In particular, any claims not expressly mentioned for damages, reduction of price, termination of or withdrawal from the contract are excluded. In no case whatsoever shall the customer be entitled to claim damages other than compensation for costs of remedying defects in the supplies. This in particular refers, but shall not be limited, to loss of production, loss of use, loss of orders, loss of profit and other direct or indirect or consequential damage. This exclusion of liability, however, does not apply to unlawful intent or gross negligence on the part of the supplier, but does apply to unlawful intent or gross negligence of persons employed or appointed by the supplier to perform any of its obligations. This exclusion of liability does not apply as far as it is contrary to compulsory law.

3. Jurisdiction and applicable law

3.1 The place of jurisdiction for both the customer and the supplier shall be at the registered office of the supplier. The supplier shall, however, be entitled to sue the customer at the latter's registered address.

3.2 The contract shall be governed by Swiss substantive law.

Important Safeguards



IMPORTANT:
READ ALL INSTRUCTIONS BEFORE USE.
RETAIN INSTRUCTIONS FOR FUTURE REFERENCE.



Do not use in rain or leave outdoors whilst raining.

WARNING: When using an electrical appliance basic safety precautions should always be observed, including the following to reduce the risk of fire; electrical shock, or injury:

- 1 Do not store or charge the unit outdoors.
- 2 Do not use outdoors or on wet surfaces.
- 3 Do not handle the charger or appliance with wet hands.
- 4 Not to be used as a toy; pay close attention when used by or near children.
- 5 This appliance is not intended for use by persons (including children) with reduced physical, sensory or mental capabilities, or lack of experience and knowledge, unless they have been given supervision or instruction concerning use of the appliance by a person responsible for their safety.
- 6 Children should be supervised to ensure that they don't play with the appliance.
- 7 Use only as described in this manual. Never modify the charger in any way.
- 8 Only use the charger supplied with the product.
- 9 Do not attempt to use the charger with any other product nor attempt to charge this product with another charger. A charger that is suitable for one type of battery pack may create a risk of fire when used with another battery pack.
- 10 Do not abuse the charger cord as this can increase the risk of fire or electric shock. Never carry the charger by the cord. Do not pull the cord to disconnect from a socket; grasp the plug and pull to disconnect.
- 11 If the supply cord is damaged, it must be replaced by the manufacturer, its service agent or similarly qualified persons in order to avoid a hazard.
- 12 If the supply cord is damaged, it must be replaced by the manufacturer, its service agent or similarly qualified persons in order to avoid a hazard.
- 13 The plug must be removed from the socket before cleaning or maintaining the appliance
- 14 Keep the charger cord away from hot surfaces and sharp edges.
- 15 Do not handle the charger with wet hands.
- 16 The battery must be removed from the appliance before it is discarded.
- 17 Before use check the power supply and charger cord for signs of damage or ageing. To avoid damage it is not recommended to wrap the cord around the charger for storage. A damaged or entangled charger cord can increase the risk of fire and electric shock.
- 18 The appliance must be disconnected from the mains supply when removing the battery.
- 19 This product includes NiMH batteries; **do not incinerate batteries or expose to high temperatures**, as they may explode.
- 20 Leaks from battery cells can occur under extreme conditions. If the liquid gets on the skin wash immediately with soap and water. If the liquid gets into the eyes, flush them immediately with clean water for a minimum of 10 minutes and seek medical attention. Liquid ejected from the battery may cause irritation or burns. In an emergency situation contact professional help immediately!
- 21 Do not use with any opening blocked; keep openings free of dust, lint, hair and anything that may interfere with the brushes.
- 22 Keep hair, clothing, fingers, and all parts of body clear of moving parts.
- 23 Do not pick up anything that is flammable, burning or smoking.
- 24 Use extra care when cleaning on stairs.



FOR INDOOR USE ONLY

The symbol indicates that this product is covered by legislation for waste electrical and electronic products (EN2002/96/EC)

When the sweeper has reached the end of its life, it and the NiMH battery it contains should not be disposed of with general household waste. The battery should be removed from the sweeper and both should then be disposed of properly at a recognised recycling facility.

Call your local council, civic amenity site, or recycling centre for information on the disposal and recycling of electrical products.



20/04/11

WARNING: Only use the charger supplied with the product.

Using another charger may damage the product and the battery and will invalidate your guarantee.

cleanfix

Cleanfix Reinigungssysteme AG Stettenstrasse 9247 Henau-Uzwil/SG
www.cleanfix.com tel: +41 71 955 47 47

cleanfix

www.cleanfix.com
tel: +41 71 955 47 47

FlooBe2

067.500

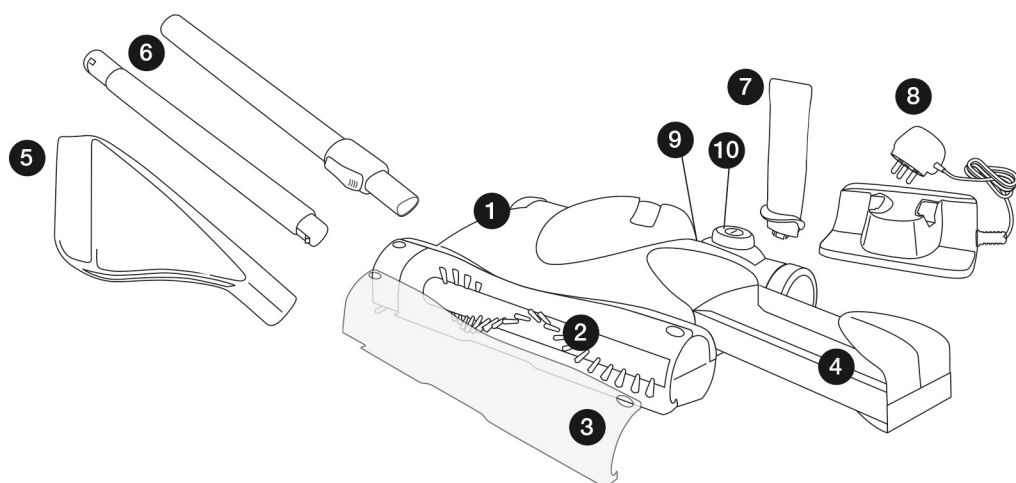

- | | |
|---------------------------|---------------------------------------|
| 1 Main Unit | 7 Lower Handle |
| 2 Brush Bar | 8 Charging Station (inside Dust Tray) |
| 3 Front Visor | 9 LED Indicator |
| 4 Dust Tray | 10 ON/OFF button |
| 5 Upper Handle | |
| 6 Telescopic Handle Tubes | |

Model FlooBe2

technical specification

Unit operating cycle with full battery	up to 120 minutes (dependent on floor surface)
Battery type	7.2V DC 2600mAh
Charging period for fully discharged battery	8 hours
Battery charger output	12V 500mA
Battery charger model	CL-CS04
Sound Level	75dB(A)
Weight	1.7Kg

WARNING: Only use a replacement battery as supplied by the manufacturer and only use the charger provided with the product. Using another charger may damage the product and battery.

1 Assembly

lower handle

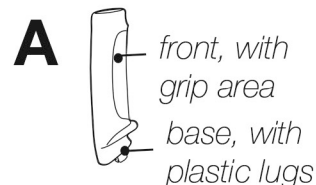

B

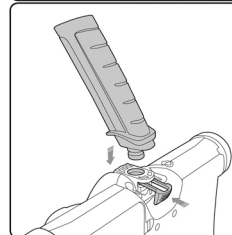
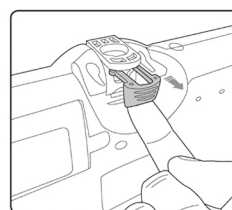
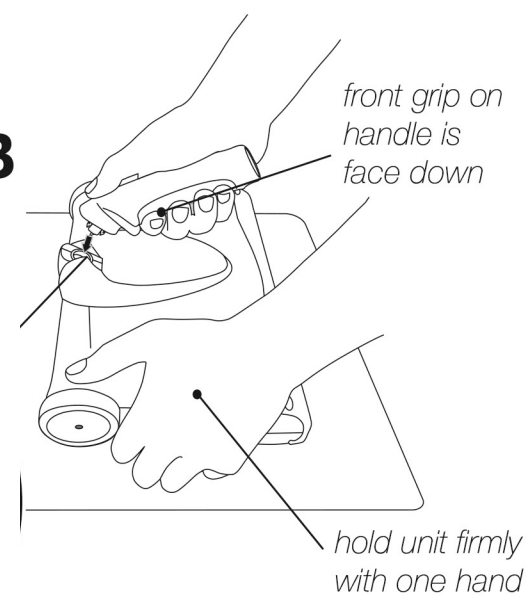

CHARGER STAND

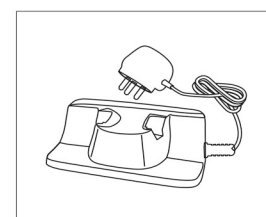

C

Telescopic Tube at the top

D

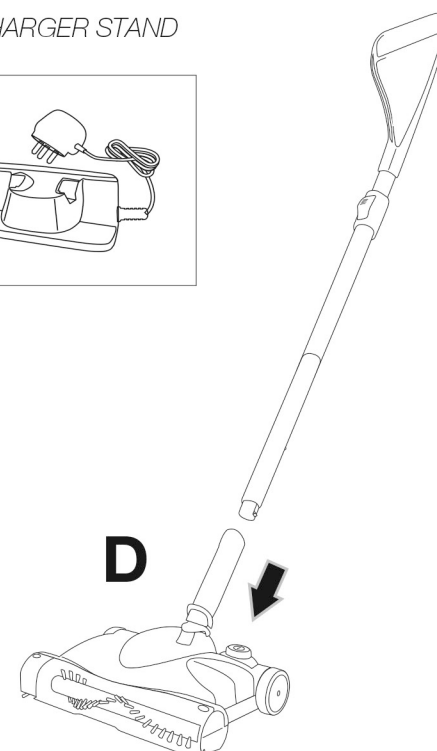

2 Operation

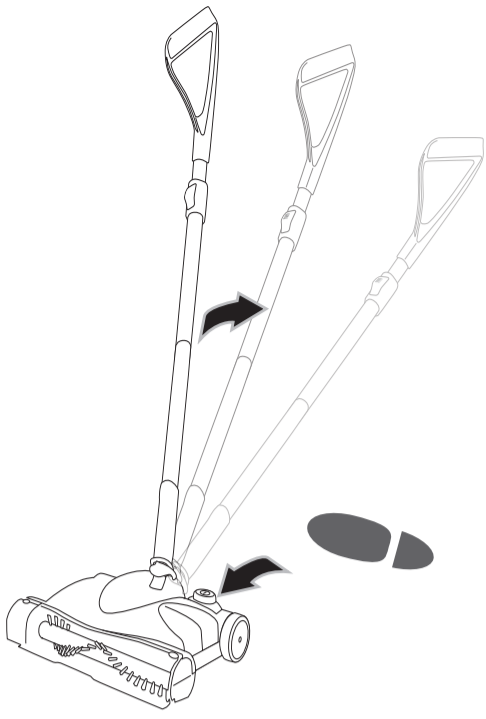

Floor Cleaning

- 1 For normal cleaning push the sweeper flat over the floor.
- 2 For deeper cleaning and carpet grooming, lift the Handle to lower the brush bar into the carpet.

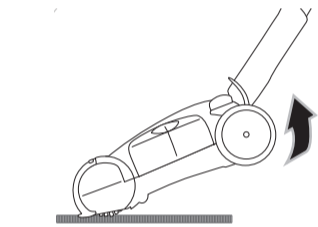

Carrying

To avoid spilling dirt from the Dust Tray do not carry the product 'nose down'.

Bin Empty

To achieve the best performance, empty the Dust Tray after each use.

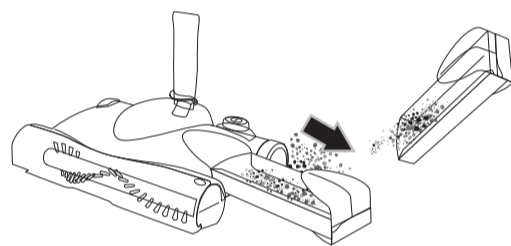

3 Battery Charging & Recharging

- 1 Plug the charging stand into an electrical outlet. Place the sweeper onto the charging stand with the rear of the unit sitting over the contacts.
- 2 The stand has a trickle charge to maintain full capacity. A totally discharged battery will take approx 8 hours to fully recharge.
- 3 The unit can be left on the charging station until it is needed for use.
- 1 **WARNING:** Only use the charger provided with the product. Using another charger may damage the product and battery.
- 2 Before use check the power supply and charger cables for signs of damage or ageing. A damaged charger can increase risk of fire or electric shock.
- 3 If the battery is damaged in any way do not attempt to charge it and replace it immediately.
- 4 Never run the battery empty and then put the product away without switching it off - deep discharge can damage the battery.

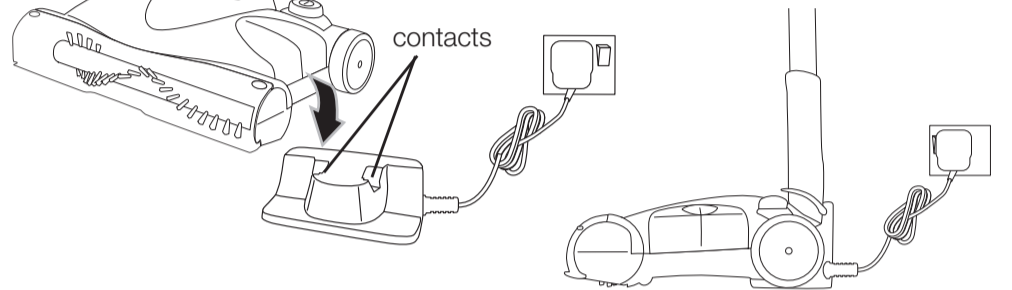

The led will illuminate red whilst the product is charging.

The red led will turn green when the unit is fully charged. The unit will only re-charge when the unit is switched off. If the unit is placed on the charging stand and there is no red light then push the on/off button once to start the charging.

To maintain peak performance of your cordless sweeper, it is recommended that the unit be fully discharged, then completely recharged at least once a month.

4 Care & Maintenance

WARNING: Do not accidentally turn the unit on while cleaning it.

Each week clean the product with a dry cloth, plus the chamber in which the Dust Tray fits. Remove hair and fibre from the Brush Bar.

- 1 Don't use abrasive materials to clean the product or immerse it in water.
- 2 Don't pick up liquids or use on wet floors.
- 3 Don't use on concrete, Tarmac or other rough surfaces.
- 4 Don't pick up pieces of string or fabrics with the unit.
- 5 Don't clean rug tassels or frayed carpets with the unit.

- 8 Refit the belt onto the drive gear.
- 9 Hook the end cover back onto the unit and push into place until the latch is securely engaged.

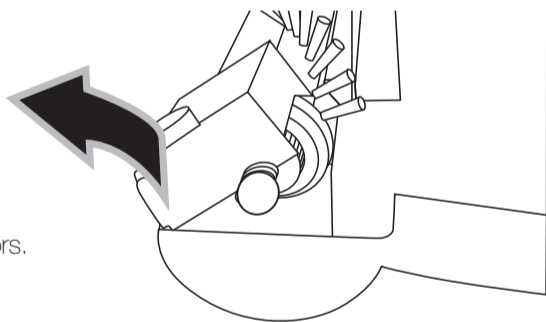

Brush Bar Removal

The Brush Bar can be removed for cleaning or replacement.

- 1 Switch off the product and ensure the charger is disconnected.
- 2 Turn the unit over, being careful not to switch the product on.
- 3 Push the latch and un-hook the end cover from the front of the unit.
- 4 Slide the belt off the end of the brush bar drive gear.
- 5 Lift the end of the brush bar, then slide out of the unit.
- 6 Remove any hair, fibre and dust from the brush bar.
- 7 Replace the brush bar by fitting the shaft into the bearing in the housing, then engage the end with the drive gear into the unit.

Note: peg to relocate into unit.

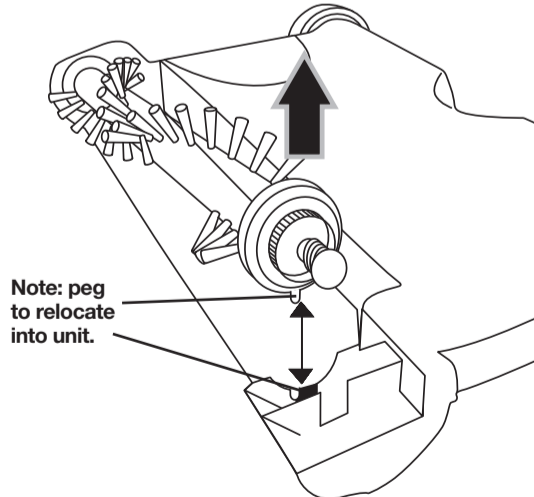

Product Is Not Working Properly?

- 1 Empty the Dust Tray.
- 2 Remove any build-up of hair or fibre from the Brush Bar.
- 3 Fully discharge the product (run until battery is flat) and then recharge for 8 hours.

5 Battery Pack Removal & Replacement

At the end of the product's or battery's life the battery should be removed for disposal and recycling. Only a technically competent person should undertake battery removal and replacement.

If uncertain as to how to replace your battery pack, we suggest you take your unit to a reputable small appliance service technician to have this service performed.

Follow these steps for battery removal or replacement:

- 1 Switch off the product and ensure the Charger is disconnected.
- 2 Remove the Telescopic Tubes and Dust Tray.
- 3 Turn the unit over, being careful not to switch the product on.
- 4 Press the clip to release the Battery Cover.
- 5 Carefully lift the battery out.
- 6 Slide the plastic cover off the black (-) cable connector.
- 7 Push the latch on the connector and pull the connector off the battery contact.
- 8 Repeat for the red (+) cable connector.
- 9 Push the cable connectors onto the new battery contacts, ensuring they are securely fitted.
- 10 Slide the plastic covers back over the connectors.
- 11 Replace the battery into the compartment and refit the battery cover.

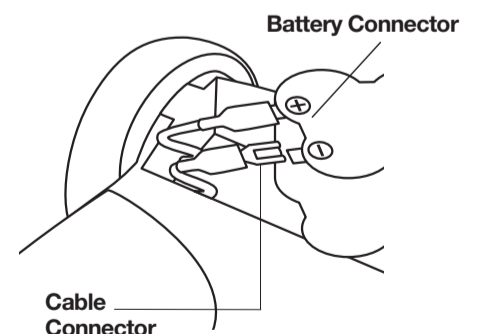
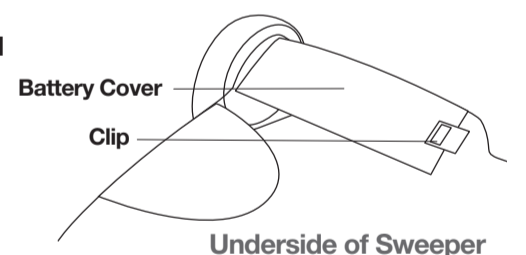

WARNING: NEVER touch both the metal battery contacts at the same time with any metal objects as this may create sparks that can cause small burns. NEVER use the unit in a partially assembled state.

ONLY USE A REPLACEMENT BATTERY AS SUPPLIED BY MANUFACTURER
Replacement batteries and brush bars can be purchased through the helpline
Tel: +41 71 955 47 47 www.cleanfix.com