



## Geared drill press

# 130601050

**Gear drill presses - SB 30 AUT**

**High Quality Geared Head Drill Press with following features:**

- Danish top quality
- Automatic feed
- Superior Finish/Design
- Rigid Construction
- Smooth and Quiet in Operation
- 350 mm throat depth
- Large working table
- 5-year guarantee on the motor
- Control panel prepared for coolant system
- Easy connection of power and coolant pump due to special connection box

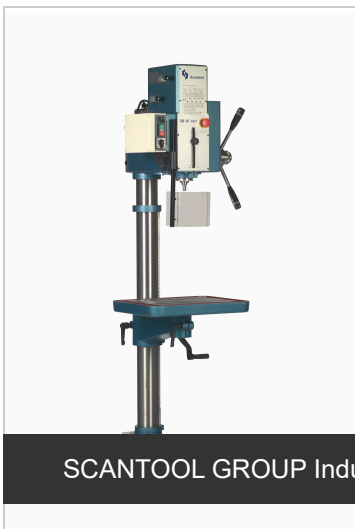



<https://scantool.dk/en/product/geared-drill-press-82>



## Product specification

Rpm	75 - 3140
Voltage	3x400V - 50Hz
Motor (HP)	1,5
Motor (kW)	1,1
Drilling Capacity (∅ mm)	32
Drilling Depth (mm)	150
Tapping Capacity	M16
Throat depth (mm)	285
Morse Taper	3
Working table (mm)	405 x 505
Distance between table & spindle (mm)	915
Distance between base & spindle (mm)	1262
Column Diameter (∅ mm)	102
Number of spindle speeds	8
Speed Numbers - Motor	2
Reversible	1
Automatic feed	1
On Pedestal	1
Height (mm)	1730
Net weight (kg)	200