

PTE 2D

Two-axis electronic folding machine

Wire diameter	2,0 to 10,0 mm
Feed speed	80 mt/min
Bending heads	2
Bending axes	2D
Accessories	Butt Welder - Frame welding
	Stamping presses
	Revolver with straightening unit
Transformer welding power	30 kvA
Cutting unit	Hydraulic
Bending radius	Min 1.5 mm
	Max 16 mm
Radius of curvature for generation	Min R = 15 mm
Reel	Motorized reel, capacity 15 Qt



PTE 3D

Three-axis electronic folding machine

Wire diameter	2,0 to 10,0 mm
Feed speed	80 mt/min
Bending heads	3
Bending axes	3D
Accessori	Butt Welder - Frame welding
	Stamping presses
	Revolver with straightening unit
Transformer welding power	30 kvA - WELDING ONLY OF 2D PARTICULARS
Cutting unit	Hydraulic
Bending radius	Min 1.5 mm
	Max 16 mm
Radius of curvature for generation	Min R = 15 mm
Reel	Motorized reel, capacity 15 Qt



EASE OF USE,
HIGH PRODUCTIVITY
AND VERSATILITY

PTE

SUCCESS AND QUALITY GUARANTEE

VARO, since 1979, has been one of the main European brands for design and supply of machines for the transformation of metal wire.

The company, founded and led by the Rota family, has established itself on the markets international thanks to the very high quality and reliability of its machines. VARO, born in a territory traditionally linked to processing and transformation of metal wire, has grown by truly focusing on the customer's needs. VARO, during the years, has been able to earn, in the eyes of sector operators, the role of partner reliable and trustworthy.

By virtue of the presence of an advanced internal mechanical department equipped with the most recent technologies in the field of machine tools, VARO is able to study and implement any possible equipment ensuring the customer maximum adherence to own project needs.

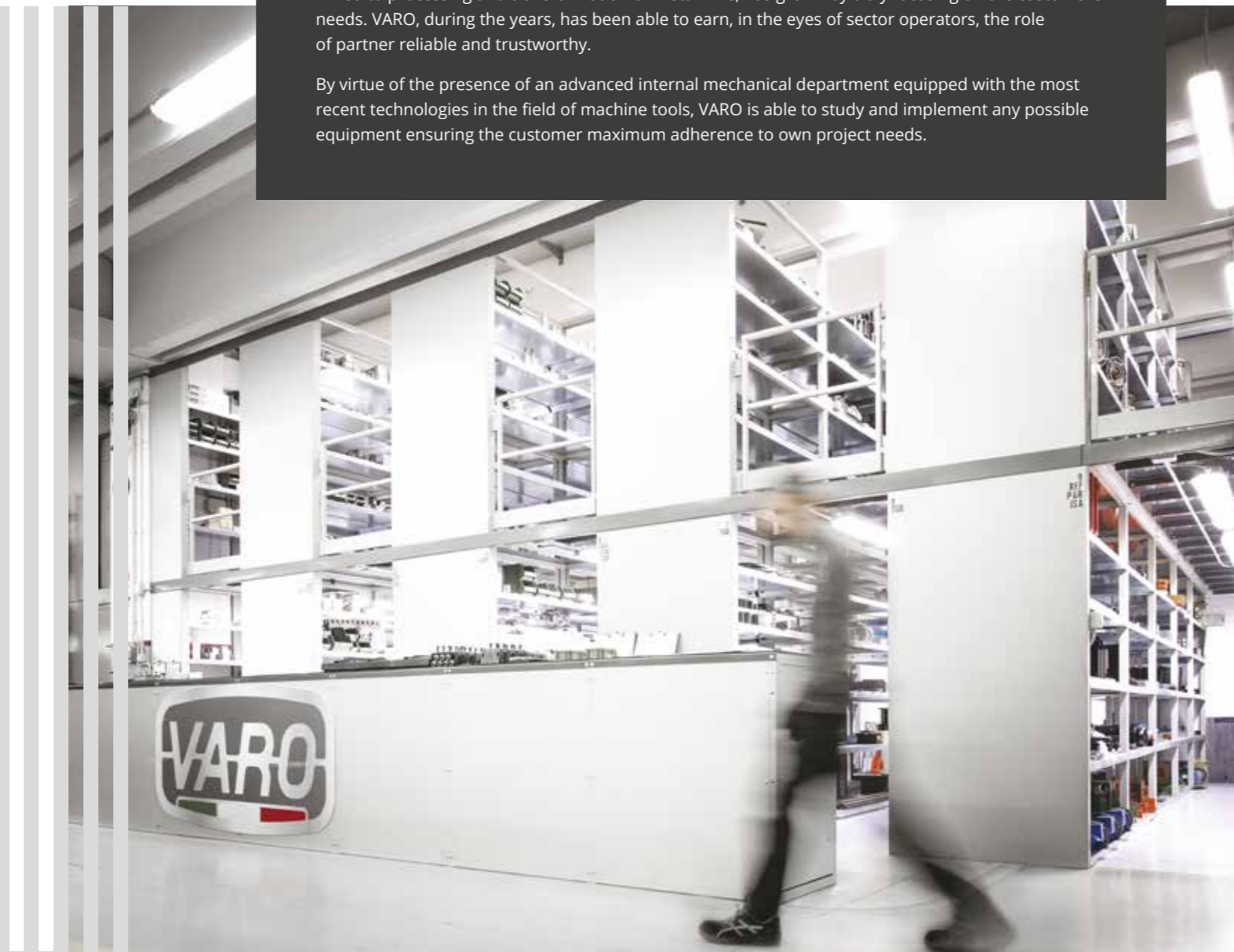

Wire processing machineries



VARO SRL

Via Roma, 87
23868 Valmadrera (LC)

+39 0341 580164
info@varo.it

Wire processing machineries

VARO.IT

PTE

Electronic 2/3 axis bending machine

- WELDING
- FORMING
- CUTTING
- ACCESSORIES
- SPECIAL LINES
- ROBOTIZED ISLE



VERSATILITY AND PRODUCTIVITY



The high storage costs and the need for continuous product changes have prompted **VARO** to create a machine that exactly meets the demands for extreme production flexibility.

PTE, combines the highest quality of the finished product with excellent productivity. The **PTE** family is suitable for both small batch production of prototypes and large-scale production. Thanks to the bending precision, guaranteed by an efficient electronic axis control, the **PTE** family has established itself as a market reference in the category of bending machines.

With its many equipment, ease of use and programming and, last but not least, the low maintenance costs, **PTE** represents the perfect balance between flexibility and productivity.



FEATURES

- Processable material
Wire - Flat strip
- Wire feeding directly from reel
- Bending head 2 or 3
- Arm rotation +/- 350 °
- Remote assistance
Internet connection
- Machine control via PC equipped with WINDOWS 10 ENTERPRISE software
- Multilingual dialogue and programming interface on touch screen
- Simulation program

PRODUCTS SHEETS



PTE 2D



PTE 3D

For more information scan the QR Code.

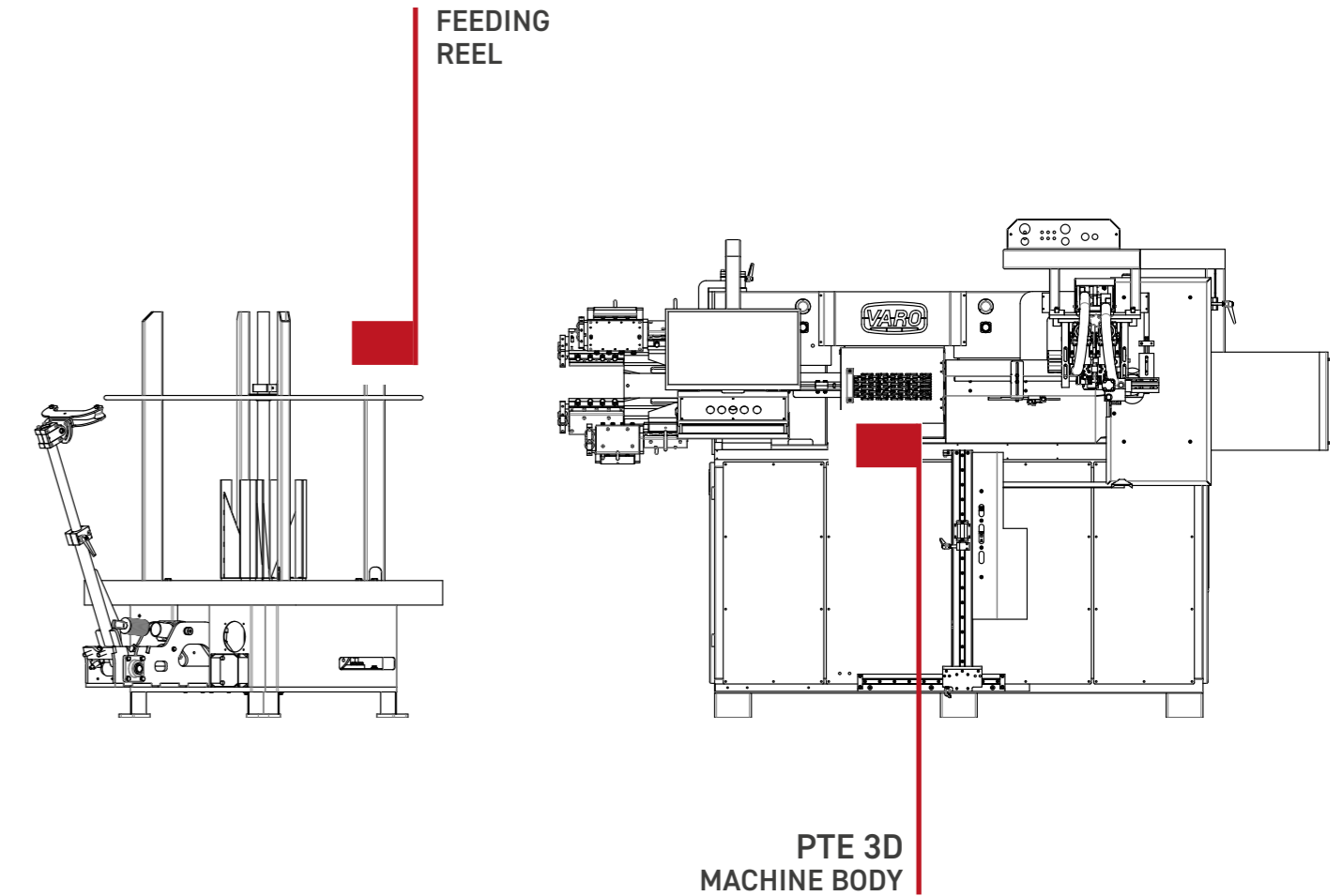
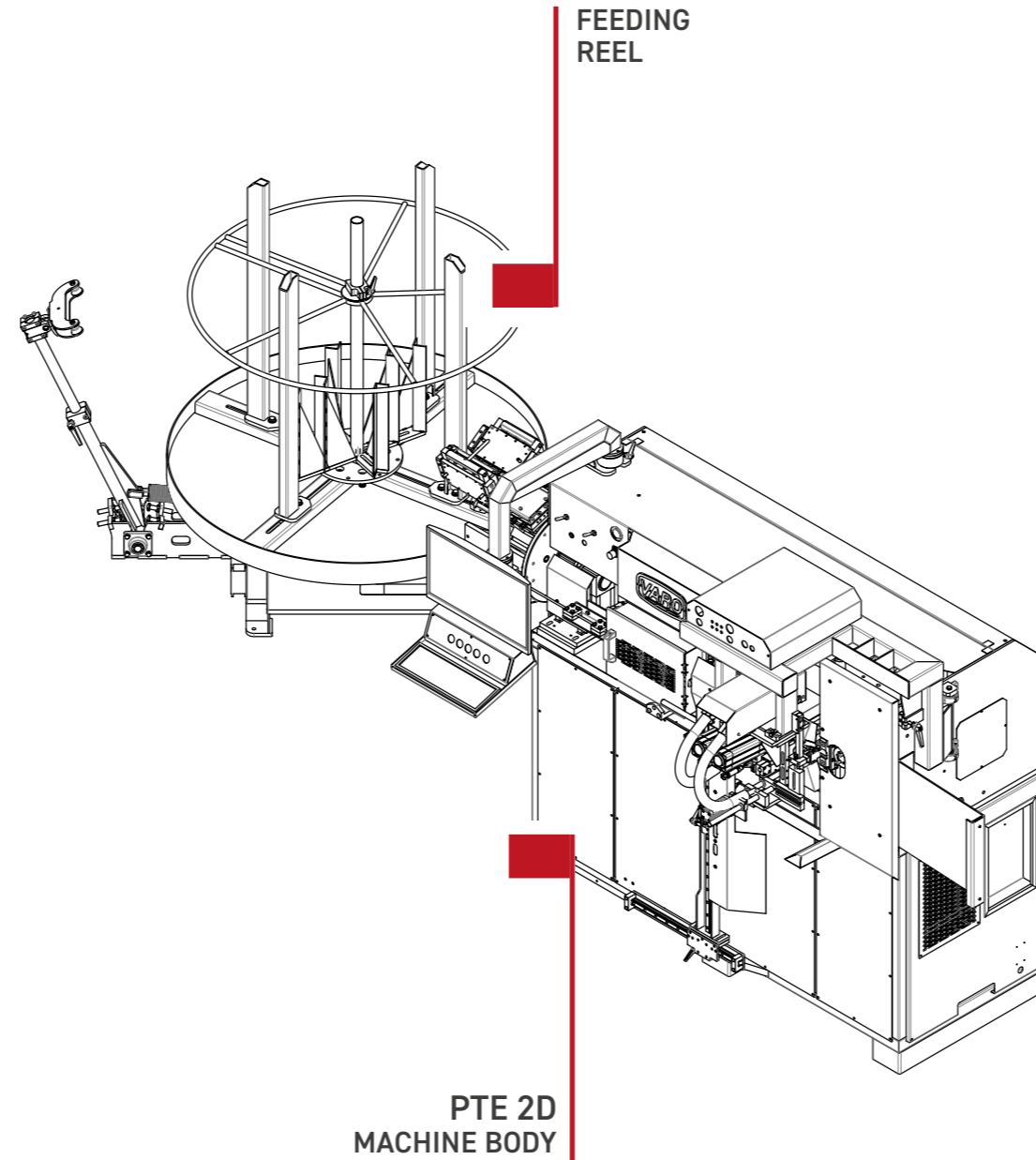

CONSTANT MONITORING

In the 4.0 set-up VARO is able to provide all the necessary and relevant information about production trends as well as about the functionality of the machine itself. The information collected allows you to have a clear view of productivity, **also available remotely and from smartphones thanks to the new MyVARO APP:**

- Alarm history
- Recipe history
- Production history

