

CATALOGUE

ALUMINIUM & PVC
Cutting machines
Windows & doors machines

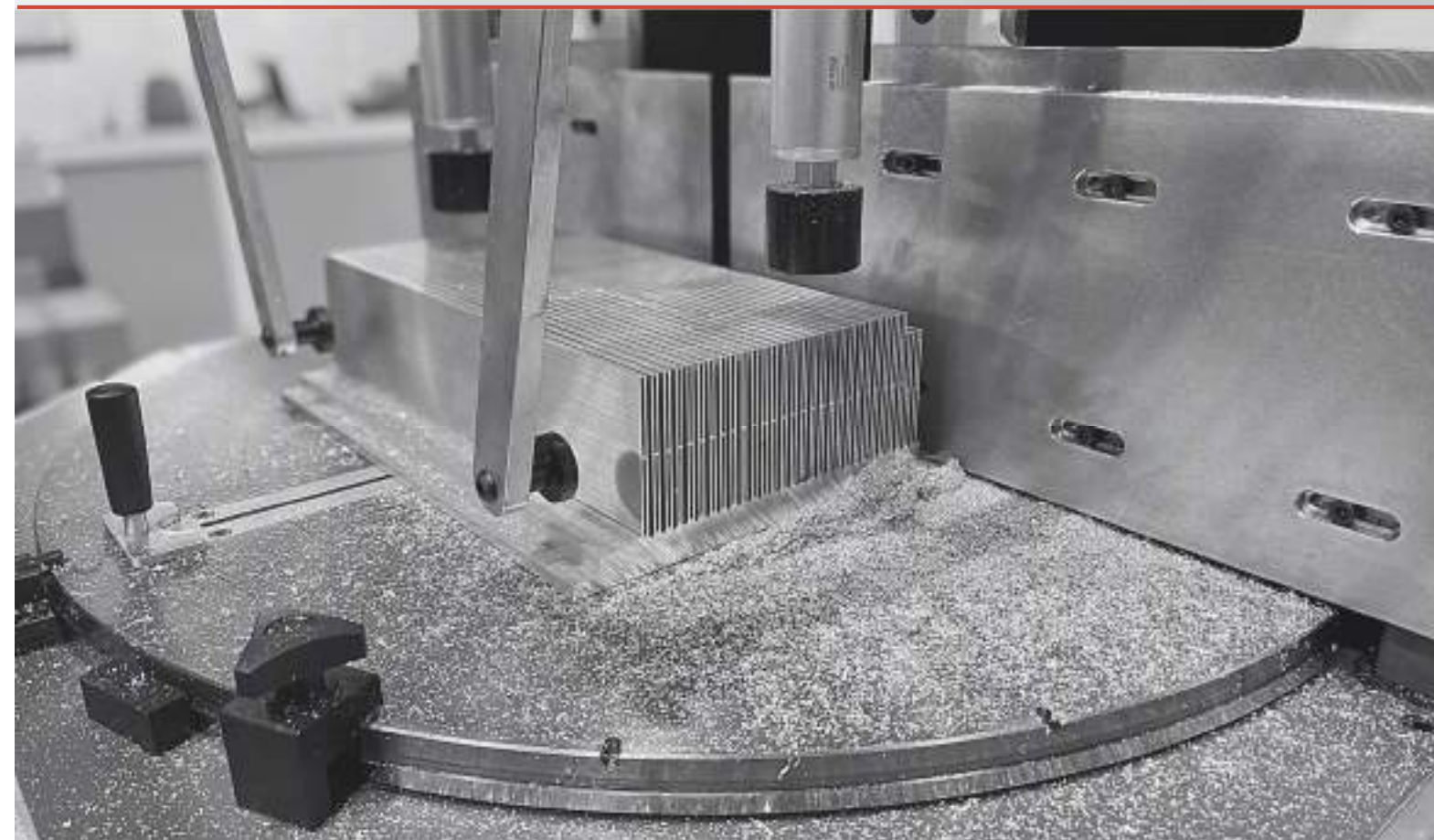

2024



www.tronzadorasmg.com



THE COMPANY

Proudly family company producing quality machines during
50 years in Spain

When the company was founded in Barcelona in 1972, the main destination of our machines was the local market of Spain. Nowadays we export to more than fifty countries worldwide, striving to manufacture enduring machines and supporting our customers with quality and personal service

We take care of every detail to produce quality and enduring machines.

We proudly produce in europe according to CE normatives and ISO 9001:2015 quality management.



INDEX OF MACHINES BY CATEGORIES

1) ALUMINIUM MITER CUTTING	Pag. 4 - 8
2) ALUMINIUM AUTOMATIC FEEDING AND MITER CUTTING MACHINE	Pag. 9 - 10
3) ALUMINIUM SINGLE BLADE 90° CUTTING	Pag. 11
4) ALUMINIUM 90° AUTOMATIC CUTTING	Pag. 12 - 14
5) AUTOMATIC PROFILES LOADER FOR GAA MACHINES	Pag. 15
6) ALUMINIUM 90° AUTOMATIC CUTTING & DRILLING	Pag. 16 - 19
7) DOUBLE MITER CUTTING MACHINE	Pag. 20
8) MACHINING CENTER	Pag. 21 - 22
9) POSITIONING SYSTEMS / ROLLER CONVEYORS	Pag. 23
10) MOTORIZED POSITIONING SYSTEMS / FEEDERS	Pag. 24
11) COPY ROUTERS FOR ALUMINIUM / PVC	Pag. 25 - 26
12) END MILLING MACHINES FOR ALUMINIUM / PVC	Pag. 27 - 28
13) PRESSES FOR ALUMINIUM PROFILES	Pag. 29
14) ASSEMBLY TABLES	Pag. 30
15) PROFILES HANDLING SYSTEMS	Pag. 31
16) VACUUM CLEANERS	Pag. 32 - 33
17) CORNER CRIMPING MACHINE / PROFILES BENDING MACHINE	Pag. 34



TL-350-SA

TL-350-M



TL-302-M » TL-350-M » Manual Clamping, Manual pumping lubrication and Manual raise of blade
 TL-302-SA » TL-350-SA » Pneumatic Clamping, Pneumatic lubrication and Manual raise of blade

Movable backfence 50mm
 Rotary Stand

	TL-302-M / SA
Blade Dimensions	300 Ø mm
Motor	2,0 HP
Motor speed	3000 rpm
Working height	950 mm
Cutting degrees	-22,5°/-45°/90°/45°/22,5°/-0°
Weight of the machine	60 kg

	TL-350-M / SA
Blade Dimensions	350 Ø mm
Motor	2,0 HP
Motor speed	3000 rpm
Working height	970 mm
Cutting degrees	-22,5°/-45°/90°/45°/22,5°/-0°
Weight of the machine	68 kg

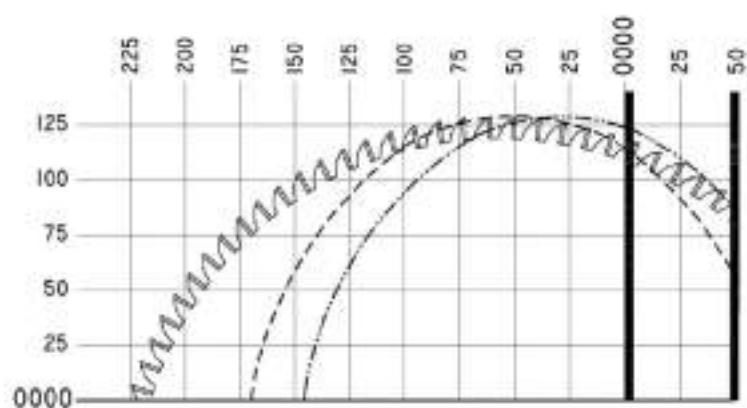
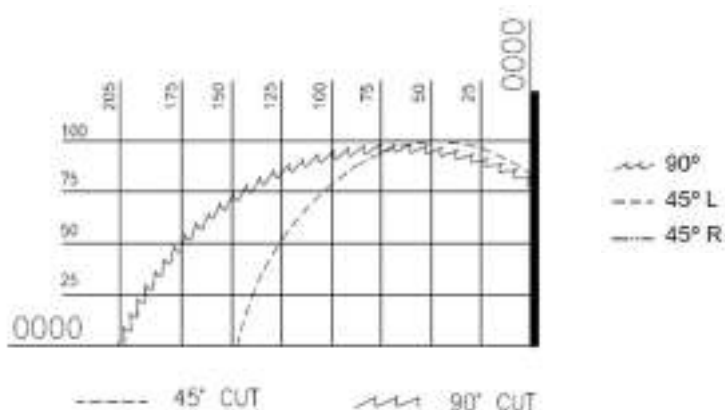

TLG-352-M

TLG-352-SA

TLG-352-A



The TLG range of miter cutting Machine for Aluminium, PVC and light metals with Ø350 mm blade and angle positioning from 0° to 180° and movable backfence 130mm to reach bigger cutting capacities

TLG-352-M » Manual Clamping, Manual pumping lubrication and Manual raise of blade

TLG-352-SA » Pneumatic Clamping, Pneumatic lubrication and Manual raise of blade

TLG-352-A » Pneumatic Clamping, Pneumatic lubrication and Pneumatic raise of blade

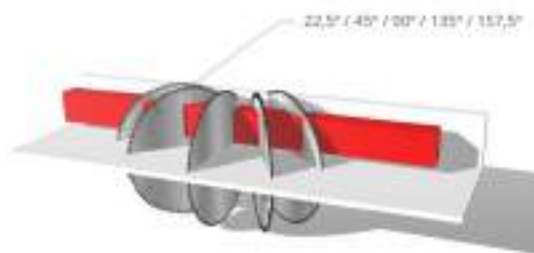

	TLG-352-M / SA / A
Blade Dimensions	350 Ø mm
Motor	2 HP (1,5 Kw)
Motor speed	3000 rpm
Working height	970 mm
Cutting degrees	0°/-22,5°/-45°/90°/135°/157,5°/180°
Weight	180 kg

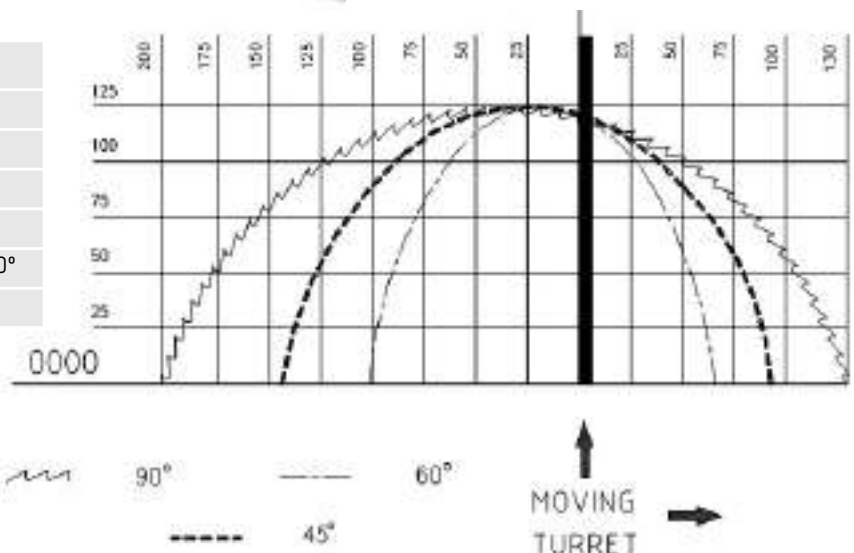

Options:
 Lubetools mist lubrication
 Digital angles display
 Laser line
 Automatic hood opening
 Led illumination

ALUMINIUM MITER CUTTING

TL-400-A



FRONT-450



	TL-400-A
Blade Dimensions	400 Ø mm
Motor	3 HP
Motor speed	3000 rpm
Working height	970 mm

	FRONT-450
Blade Dimensions	450 Ø mm
Motor	3 HP
Motor speed	3000 rpm
Working height	970 mm

22,5° / 45° / 90° / 135° / 157,5°
MANUAL

22,5° / 45° / 90° / 45° PNEUMATIC

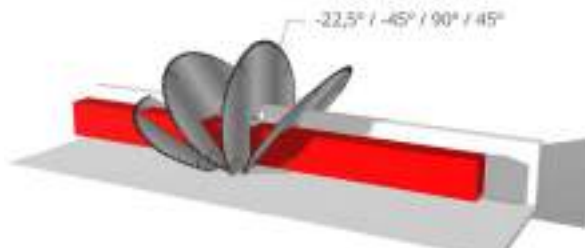

CUTTING CAPACITY

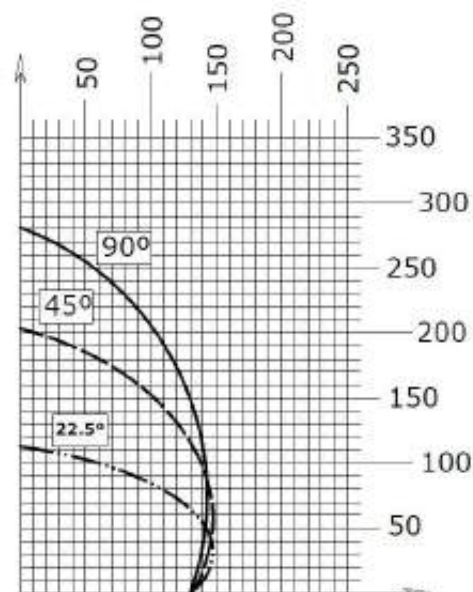
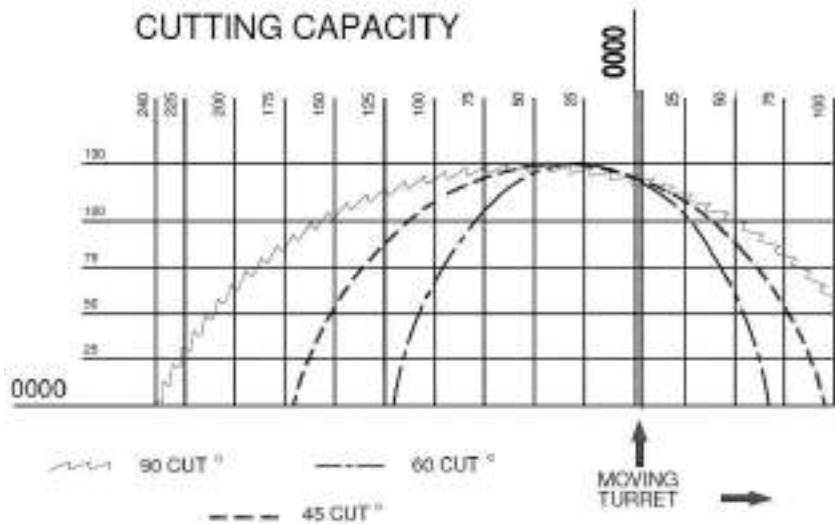

TL-500-A



	TL-500-A
Blade Dimensions	500 Ø mm
Motor	4 HP (3,0 Kw)
Motor speed	3000 rpm

TL-600-A



	TL-600-A
Blade Dimensions	600 Ø mm
Motor	4 HP (3 Kw)
Motor speed	3000 rpm

22,5° / 45° / 90° / 135° / 157,5°
MANUAL

Options:
Lubetools mist lubrication
Digital angles display
Laser line
Automatic hood opening
Led illumination

Options:
Motor 4 Kw (5,3HP)
Motor 5,5 Kw (7,5 HP)
22,5° / 45° / 90° / 135° / 157,5°
MANUAL

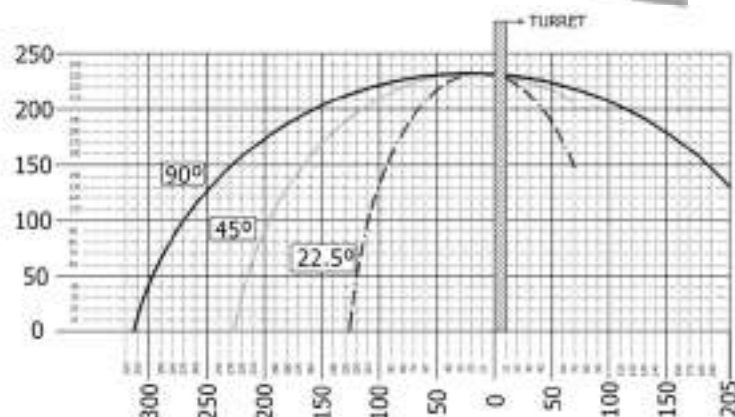
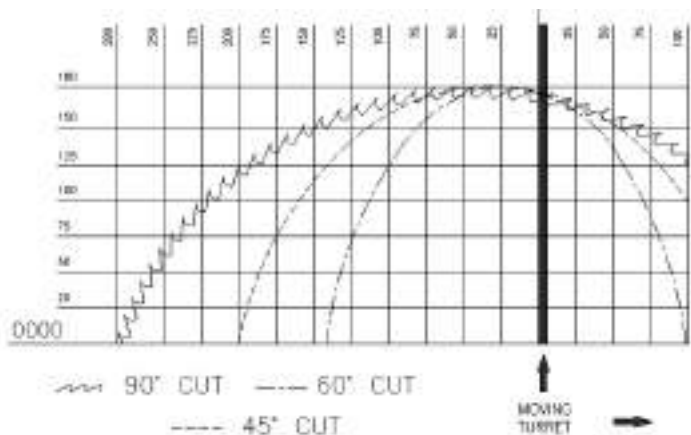

TL-650-A



	TL-650-A
Blade Dimensions	650 Ø mm
Motor	7,5 HP (5,5 Kw)
Cutting speed	55 m/sec
Working height	970 mm
Cutting degrees	-22,5°/-45°/90°/45°/22,5°

TL-800-A



	TL-800-A
Blade Dimensions	800 Ø mm
Motor	10 HP (7,5 Kw)
Cutting speed	30-70 m/sec
Working height	970 mm
Cutting degrees	-22,5°/-45°/90°/45°/22,5°

22,5° / 45° / 90° / 135° / 157,5°
MANUAL



Options:
Lubetools mist lubrication
Digital angles display
Laser line
Automatic hood opening
Led illumination

22,5° / 45° / 90° / 135° / 157,5°
MANUAL

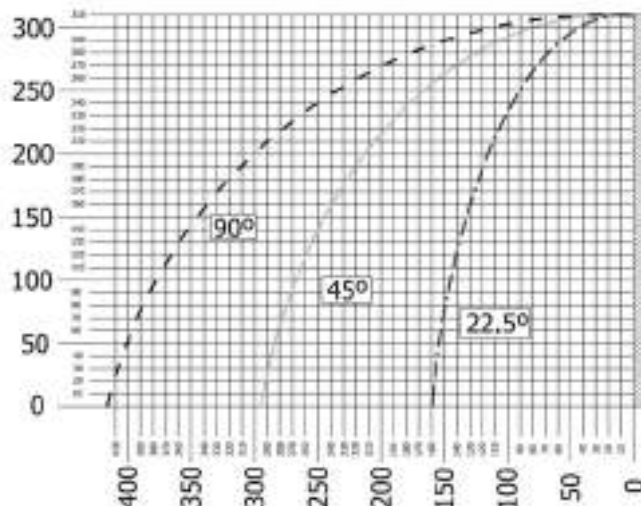
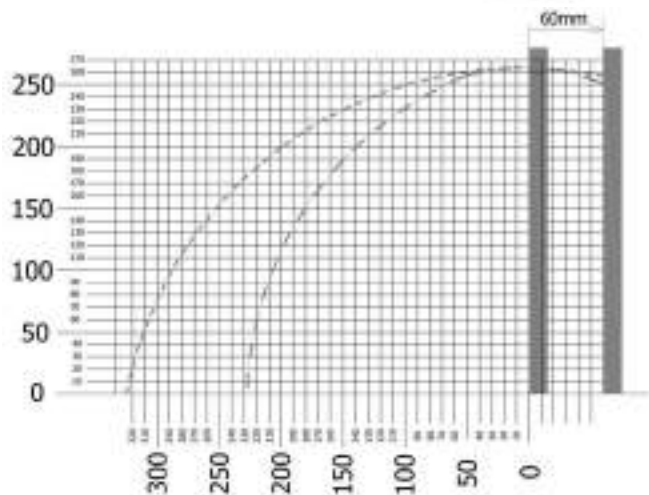

FRONT-450 CNC AAG

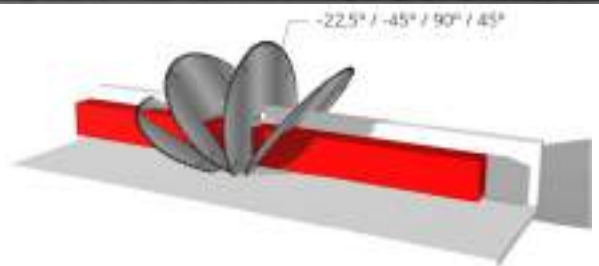
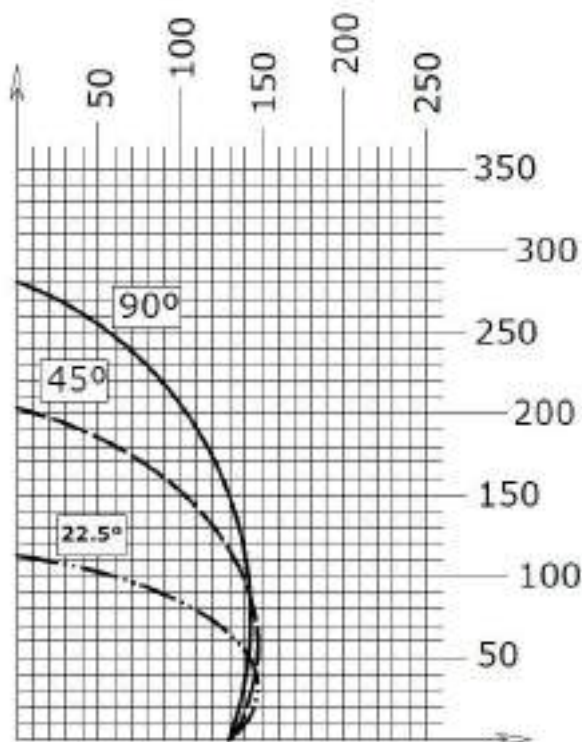

The FRONT-450 AAG CNC is a fully automatic cutting Machine with feeding and automatic blade turning with oleopneumatic cylinders reaching angles from 22,5° to 135°



	FRONT-450 AAG CNC
Blade Dimensions	450 Ø mm
Motor	3 HP (2,2 Kw)
Motor speed	3000 rpm

TL-600-AAG CNC



45° to 135° automatic blade turning by Servo motor

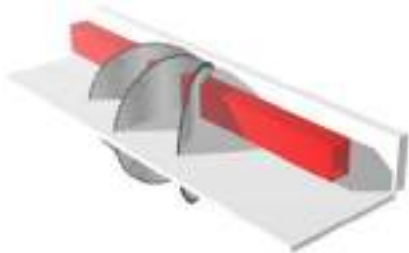

Automatic turning of the blade by servo motor to intermediate angles

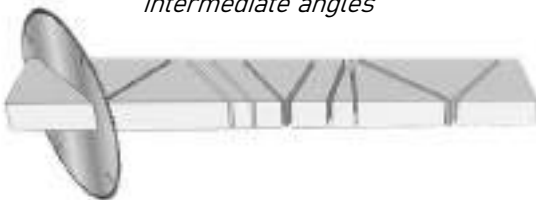

The TL-600 AAG CNC is a fully automatic cutting Machine with feeding and automatic blade turning with servo motor reaching angles from 45° to 135°

The programmable controller working with a 5,6" color Touch screen panel, accepts 10 programs, and 30 cutting list lines in each program. It also accepts a library of 20 parts

	TL-600-AAG CNC
Blade Dimensions	600 Ø mm
Motor	4 HP (3,0 Kw)
Motor speed	3000 rpm

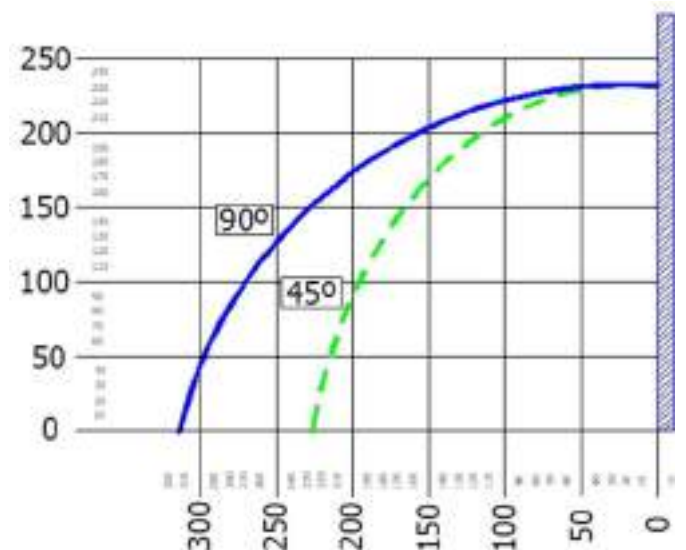

ALUMINIUM SINGLE BLADE 90° CUTTING



TL-600-90

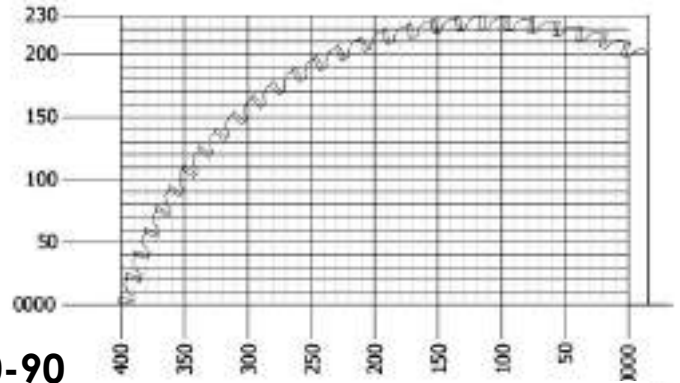

TL-650-90

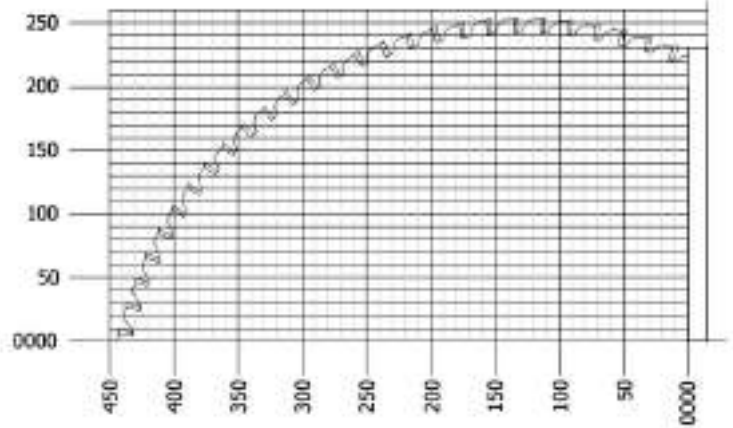

TL-700-90

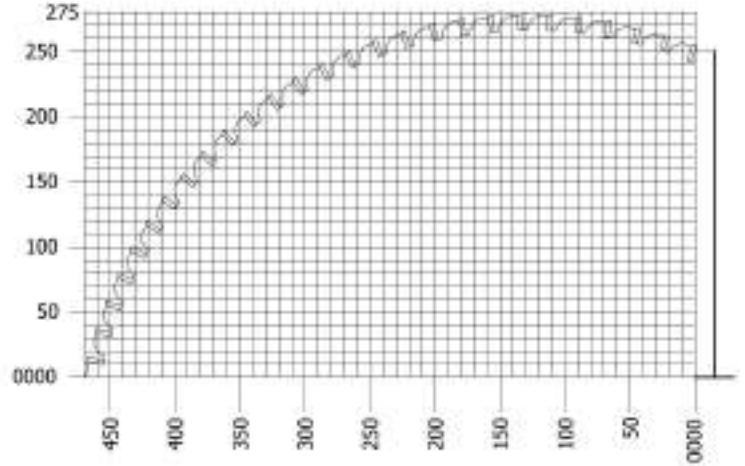

TL-800-90

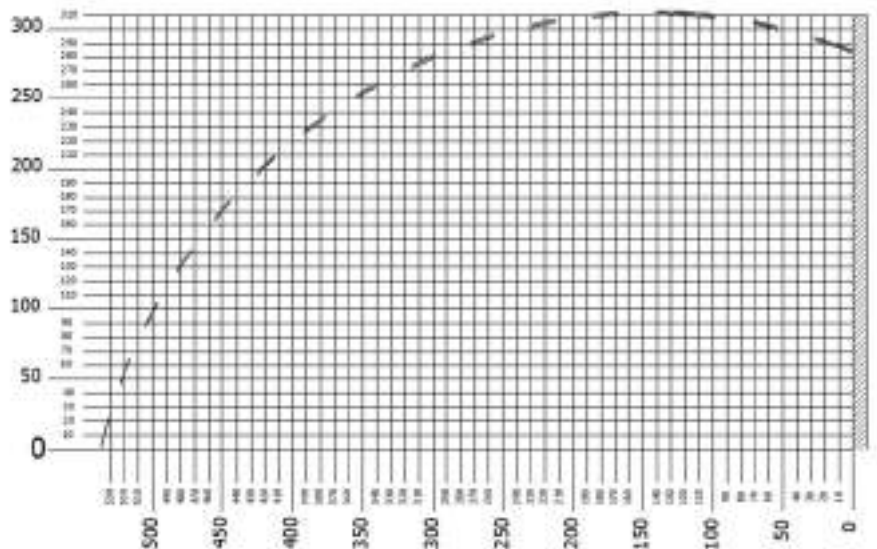

	TL-600-90
Blade Dimensions	600 Ø mm
Motor	5,5 HP (4,0 Kw)
	TL-650-90
Blade Dimensions	650 Ø mm
Motor	7,5 HP (5,6 Kw)
	TL-700-90
Blade Dimensions	700 Ø mm
Motor	7,5 HP (5,6 Kw)
	TL-800-90
Blade Dimensions	800 Ø mm
Motor	10 HP (7,5 Kw)

GAA-350-90



GAA-500-90



	GAA-350-90
Blade Dimensions	350 Ø mm
Motor	2,5 HP (1,8Kw)
Motor speed	3000 rpm
Feeder length	300 mm
Cutting degrees	90°

	GAA-500-90
Blade Dimensions	500 Ø mm
Motor	4 HP (3Kw)
Motor speed	3000 rpm
Feeder length	500 mm
Cutting degrees	90°

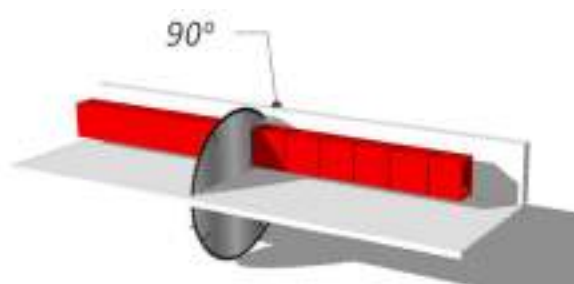
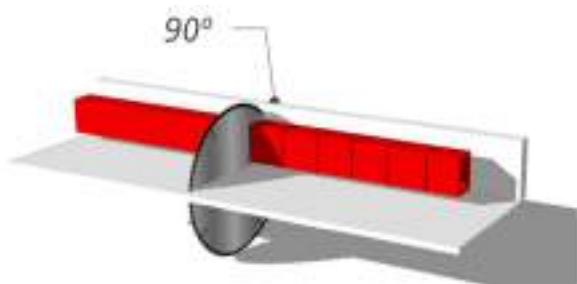

*LED illumination incl.
Automatic hood opening incl.*

*Options:
Lubetools mist lubrication
Automatic start/stop of vaccum cleaner*

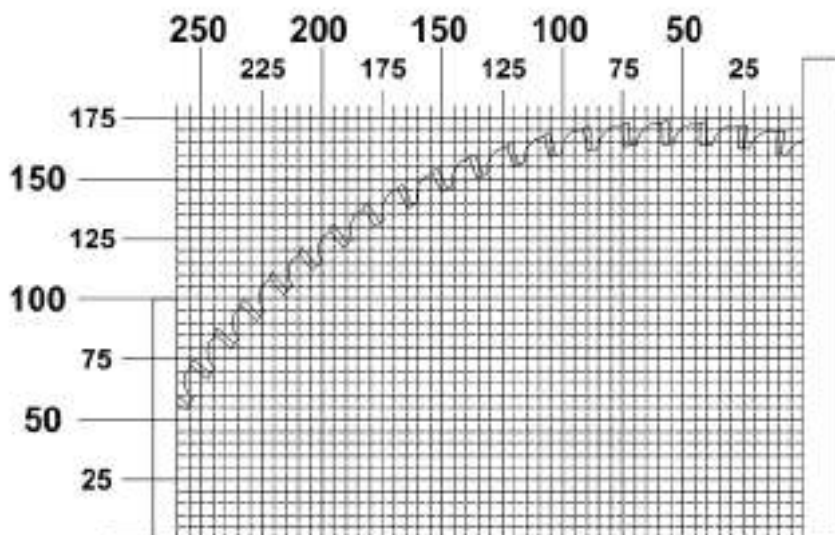
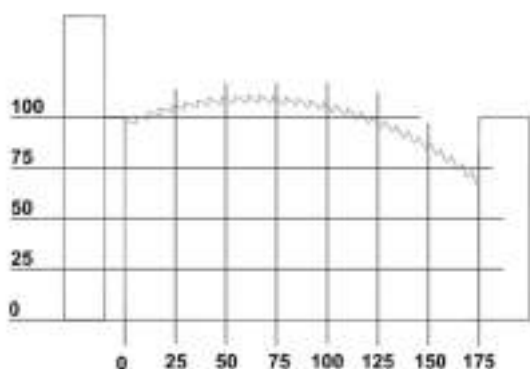

GAA-350-90 CNC



GAA-500-90 CNC



GAA-350-90 CNC

Blade Dimensions	350 Ø mm
Motor	2,5 HP (1,8Kw)
Motor speed	3000 rpm
Feeder length	700 mm
Cutting degrees	90°

GAA-500-90 CNC

Blade Dimensions	500 Ø mm
Motor	4 HP (3Kw)
Motor speed	3000 rpm
Feeder length	700 mm
Cutting degrees	90°

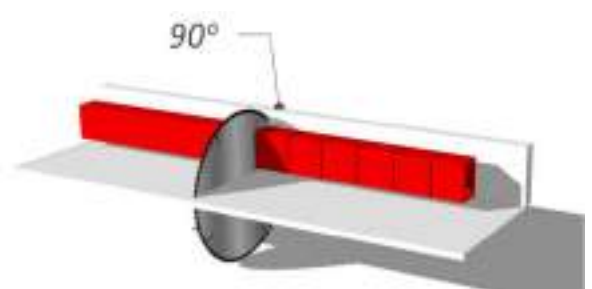
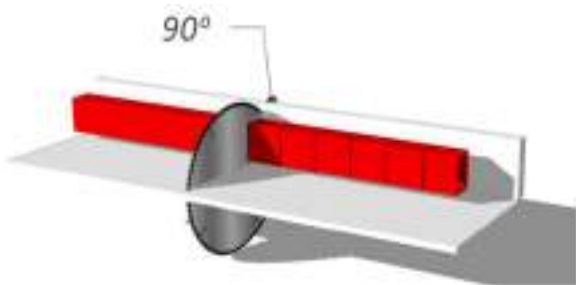

LED illumination incl.
Automatic hood opening incl.

Options:
Lubetools mist lubrication
Blade RPM regulation
Automatic start/stop of vaccum cleaner
Ethernet connection

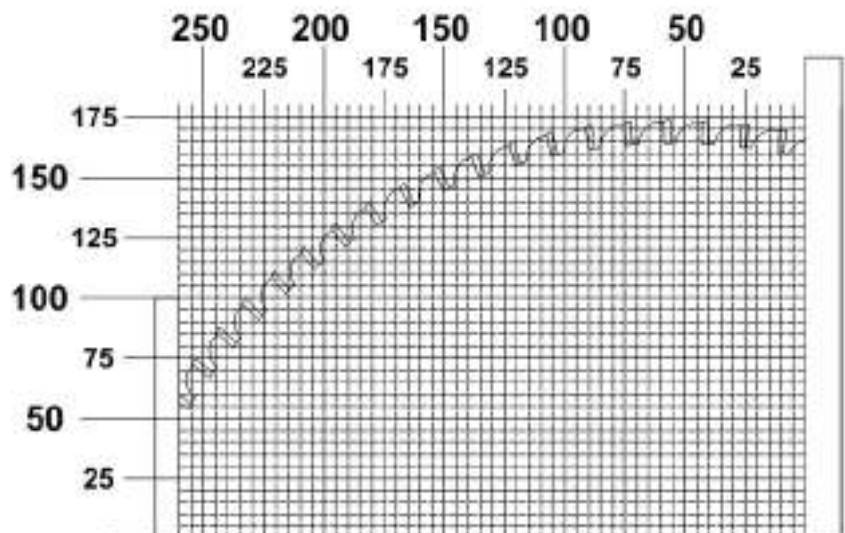
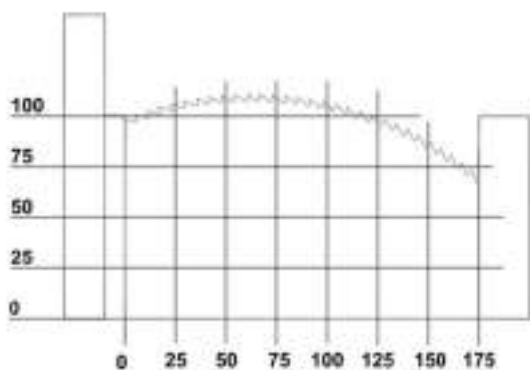

ALUMINIUM 90° AUTOMATIC CUTTING



GAA-600-90

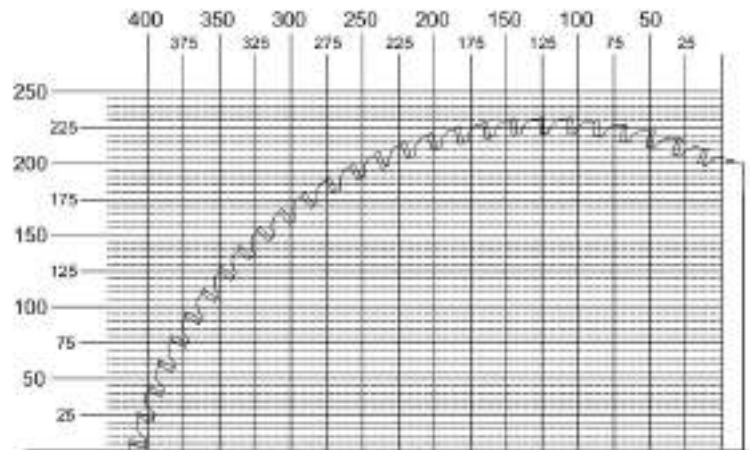

GAA-650-90

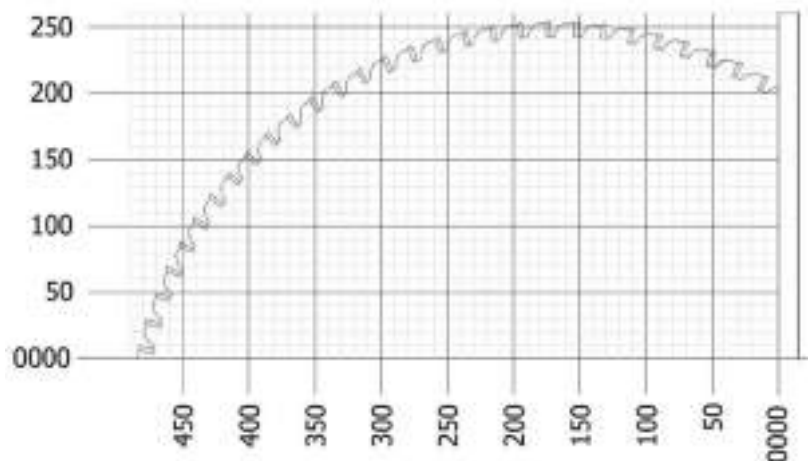

GAA-800-90

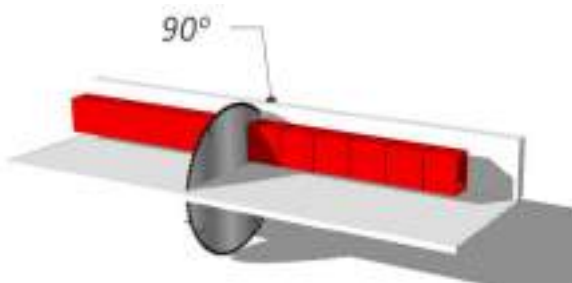
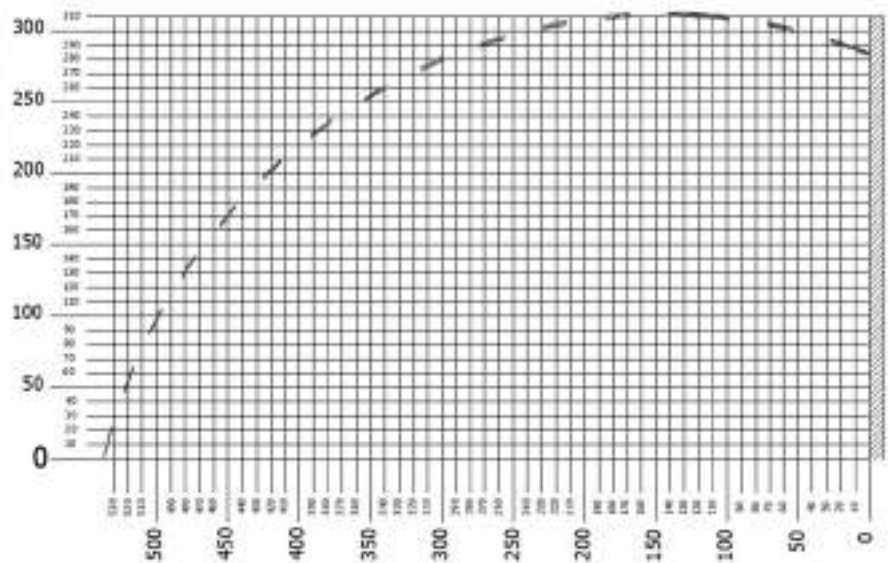

	GAA-600-90 / CNC
Blade Dimensions	600 Ø mm
Motor	5,5 HP (4 Kw)
Feeder length	500 mm / 700mm servo
Cutting degrees	90°

	GAA-650-90 / CNC
Blade Dimensions	650 Ø mm
Motor	7,5 HP (5,5 Kw)
Feeder length	500 mm / 700mm servo
Cutting degrees	90°

	GAA-800-90 / CNC
Blade Dimensions	800 Ø mm
Motor	10 HP (7,5 Kw)
Feeder length	500 mm / 700mm servo
Cutting degrees	90°

AUTOMATIC LOADER OF PROFILES FOR GAA MACHINES

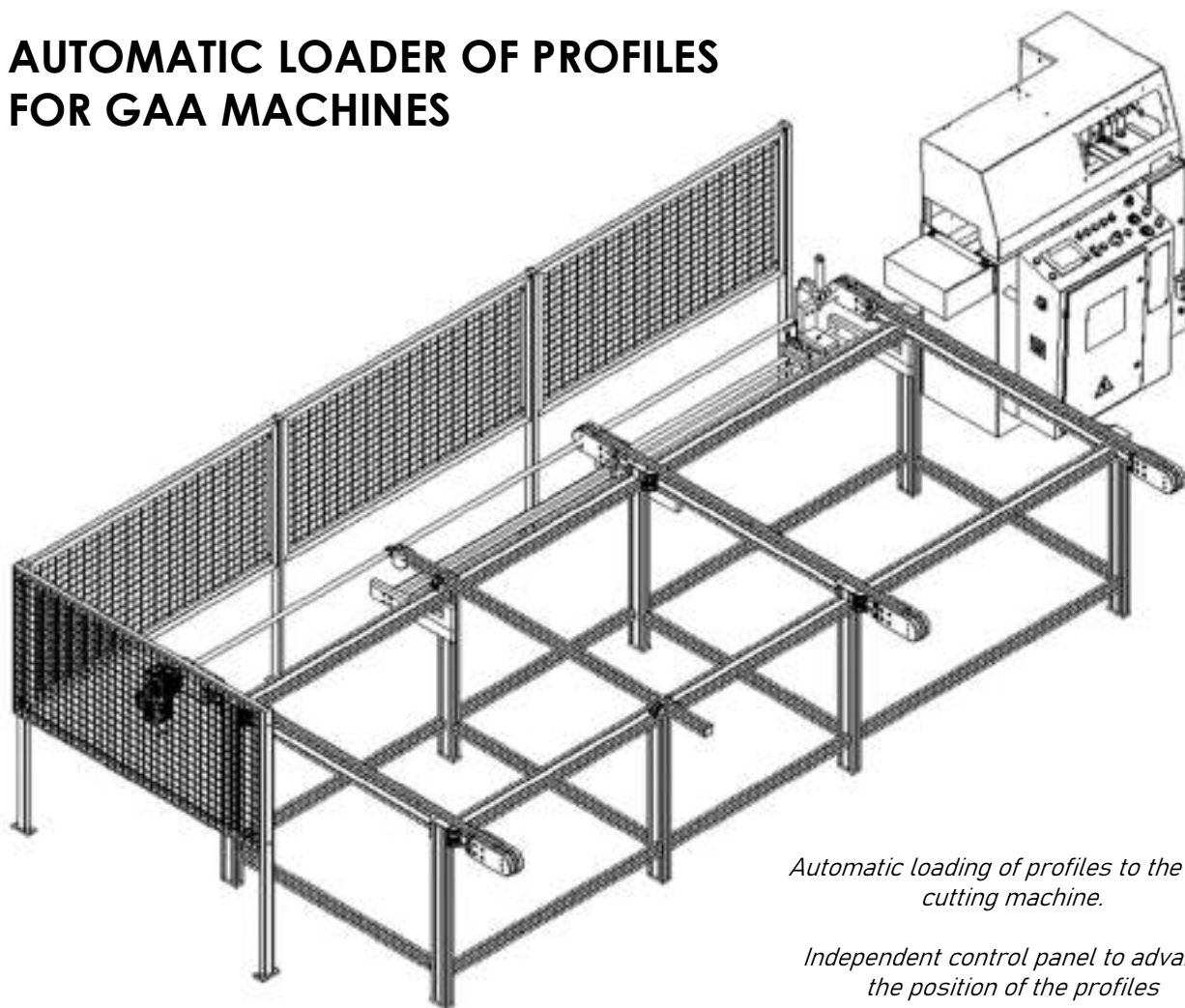

Automatic loading of profiles to the GAA cutting machine.

Independent control panel to advance the position of the profiles

Safety fence included with back door for maintenance

	AUTOMATIC LOADER
Dimensions	6000 x 2000mm standard
Profiles QTY	Average 10



GAA-350 CNC / TR12



*Automatic CNC Cutting, drilling and tapping Machine with one vertical drilling unit for Ø12 mm and M10
OMRON controllers
20 Parts in library memory
10 programs with 30 cutting lines each program
20 holes drilling per piece
X axis feeder*

Options:
Y axis movement on drilling unit
TR20 drilling unit for Ø20 mm and M16
T14 SERVO drilling unit with servo drive



GAA-350 CNC / TR12 V / TR12 H

Automatic Cutting, drilling and tapping Machine with one vertical drilling unit and one horizontal drilling unit

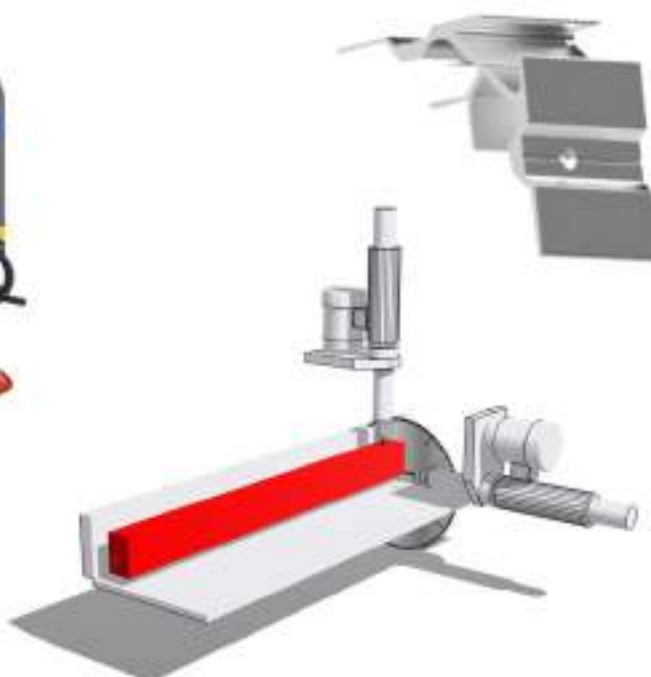

GAA-350 CNC/TR12 V/TR12 H/TR12 F

Automatic CNC Cutting, drilling and tapping Machine with one vertical drilling unit, one horizontal drilling unit and Frontal drilling unit



GAA-350 CNC/TR12 V+Y /TR12 H+Z

Automatic CNC Cutting, drilling and tapping Machine with SERVO X axis feeder, one vertical drilling unit with SERVO Y axis movement and one horizontal drilling unit with SERVO Z axis movement



GAA-500 CNC / TR12 H / TR12 H



Special CNC cutting and drilling Machines specially made for custom parts



Automatic CNC Cutting, drilling and tapping Machine with one vertical drilling unit, and two horizontal adjustable units

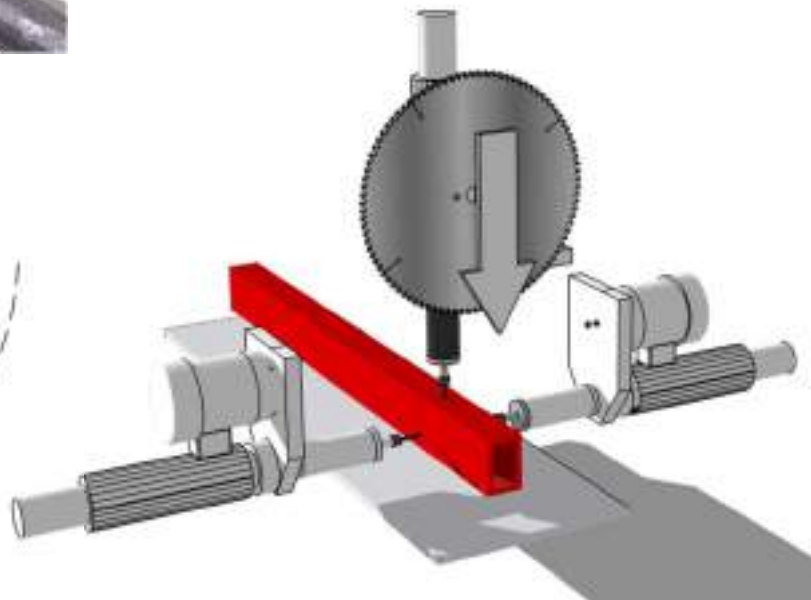
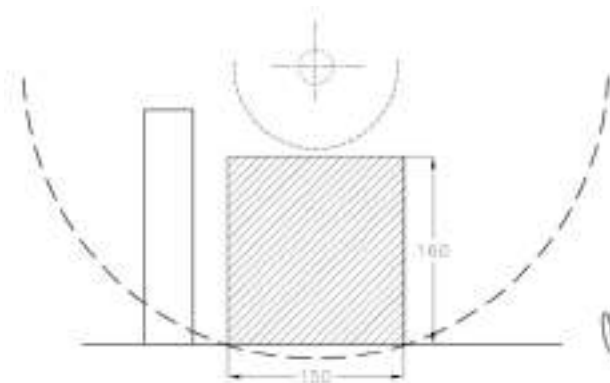

GAA-350 CNC PUNCHING FOR SOLAR CLIPS



Specially designed GAA-350 Machine with automatic profiles loader for three bars processing simultaneously



GAA-350 automatic cutting and punching Machine for three profiles at the same time with very high production rate for solar panels clips

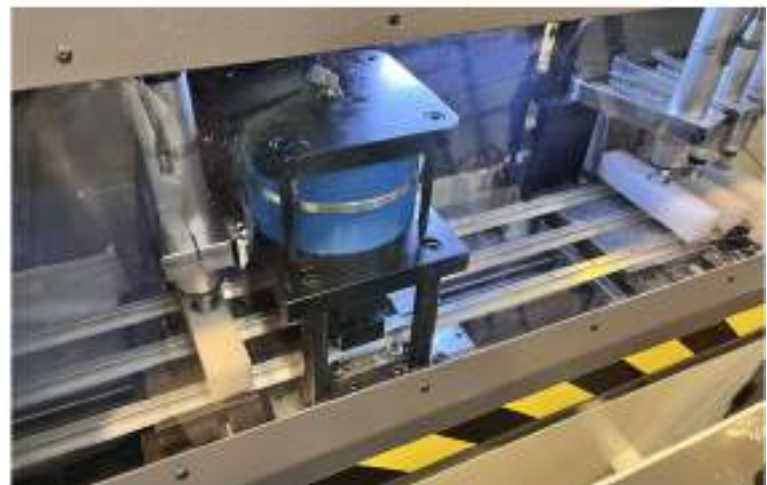

DOUBLE MITER CUTTING MACHINE

DUO-450 / DUO-550



	DUO-450		DUO-550
Blade Dimensions	450 Ø mm	Blade Dimensions	550 Ø mm
Cutting degrees	-45° / 90° / 45°	Cutting degrees	-45° / 90° / 45°
Weight of the machine	1400 kg	Weight of the machine	1600 kg

-45° / 90° / +45°
PNEUMATIC

9500mm longer cut part
5mm smaller cut part

-45° / 90° / +45°
PNEUMATIC

Four working modes:
AUTOMATIC MODE
SEMI-AUTOMATIC MODE
MANUAL MODE
STEP BY STEP CUTTING MODE

Options:
Profile height caliper
Label Printer
Barcode Scanner

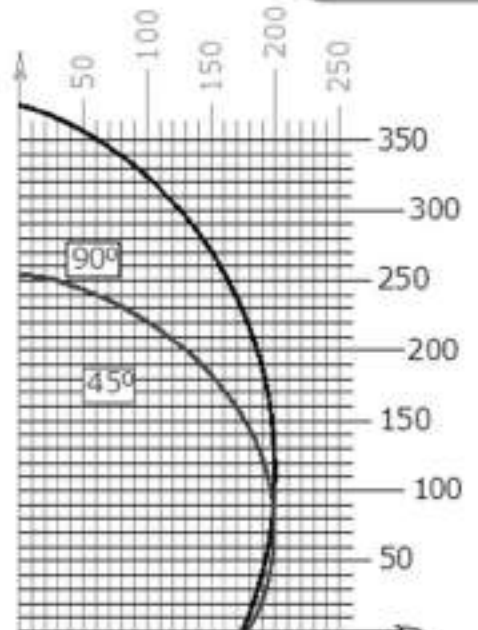
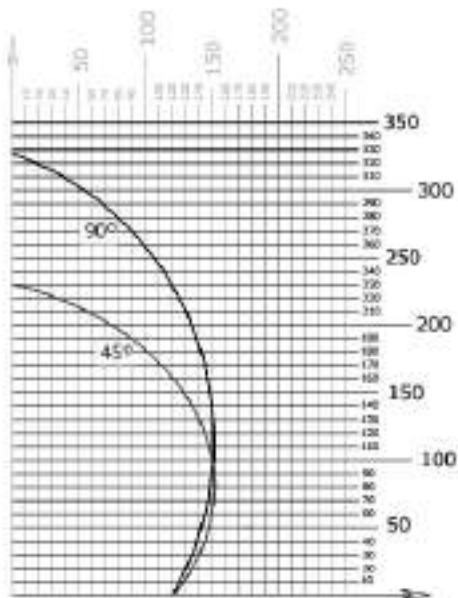
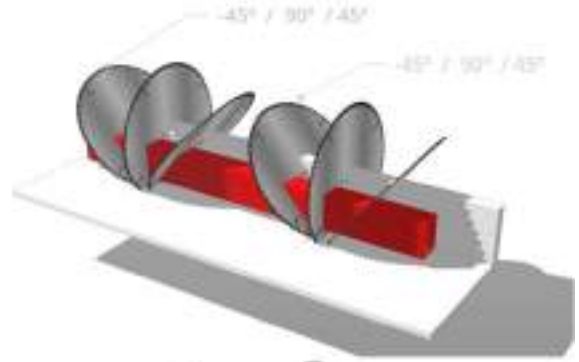
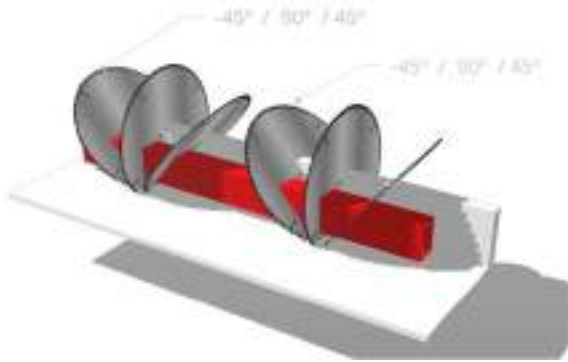

MG-3300/4

4-Axis Machining Center



4axis machining center
 5,5 Kw HITECO with spindle rotation of 18000rpm
 5mm Aluminium / 3mm Steel

X4 pneumatic clamping
 4 tools magazine (option 8)
 HICAM3 CAD/CAM 3D design

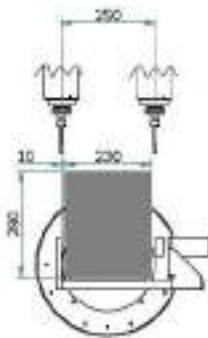

ONLY AT 0° INSIDE THE RINGS

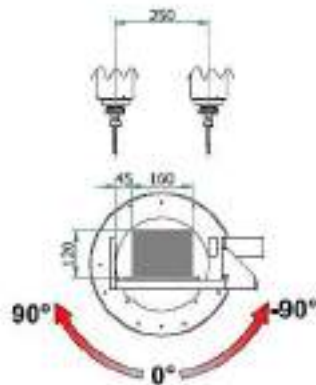

THROUGH THE RINGS

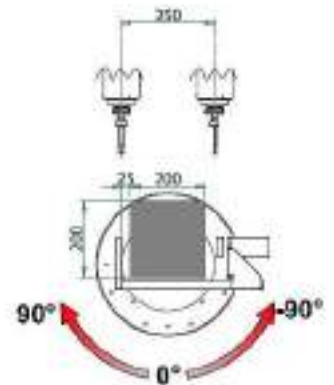

INSIDE THE RINGS

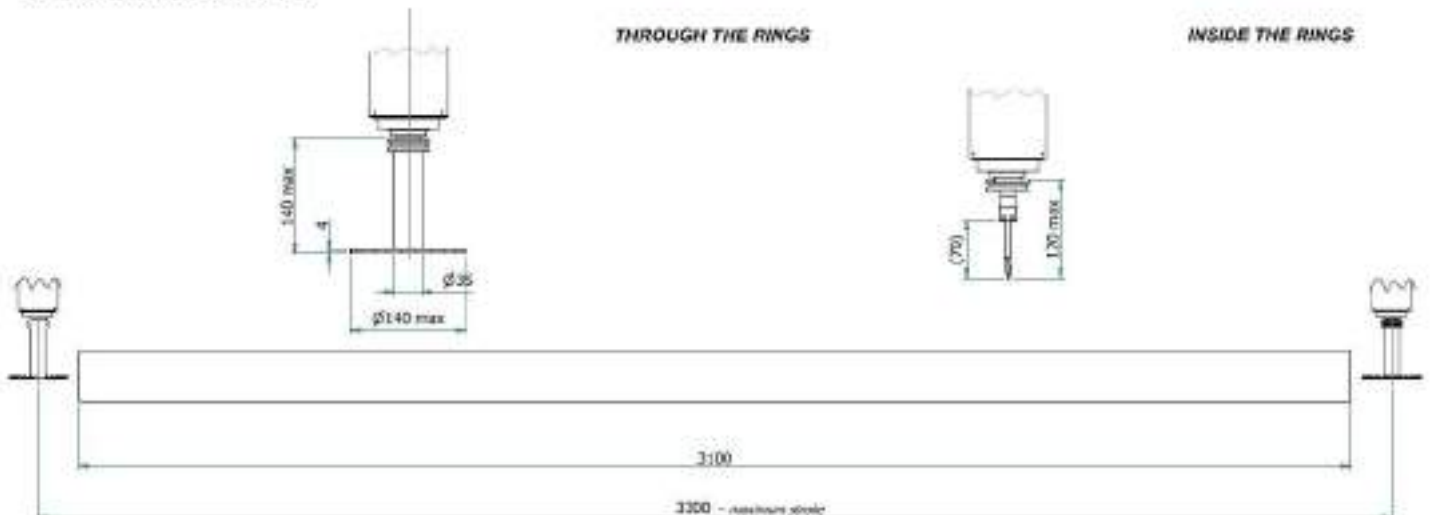

MG-3300/4

4-Axis Machining Center

FEATURES

- Possibility to work aluminum, PVC, steel up to 5 mm and stainless steel up to 3 mm with accessory
- Axis movement and clamps rails with recirculating ballscrew and servodrive
- Motion rotated clamp base by rail and wheels
- Numerically controlled axes with 4 brushless motors
- Transmission axis with tilted teeth rack and pinion
- Start cycle with two-handed safety device
- 4 pneumatic horizontal pneumatic clamps with low pressure device
- Mist lubrication
- Tool magazine ISO30
- Automatic tool change with station for 4 tools (optionally 8 tools)
- 5,5 Kw Spindle motor driven by inverter
- USB 2.0 port on the control panel and ethernet RJ45 socket
- Preinstalled barcode reader connection
- NC - Industrial PC with Intel microprocessor
- LCD display - TFT (800 x 600) color 10.4 "
- Operating system Windows XP Embedded RT
- HICAM 3 Software- 3D dimensional

TECHNICAL DATA

Power (3 phase+neutral)	380/400-50/60	Volt/Hz
Spindle motor	5.5	Kw
Spindle speed range	2000...18000	rpm
Axis positioning range X-Y-Z	3300 -250-200	mm
Axis positioning speed X- Y-Z	65-25-25	m/min
Tilt axis adjustable clamp	-90°...+90°	°
Axis time rotation from 0 .. 90 °	2	Sec
Axis positioning tolerance	3 +/- 0.1	mm
Clamping capacity (bxh)	160x120	mm
Max. milling blade diameter	140	mm
Weight	1550	Kg

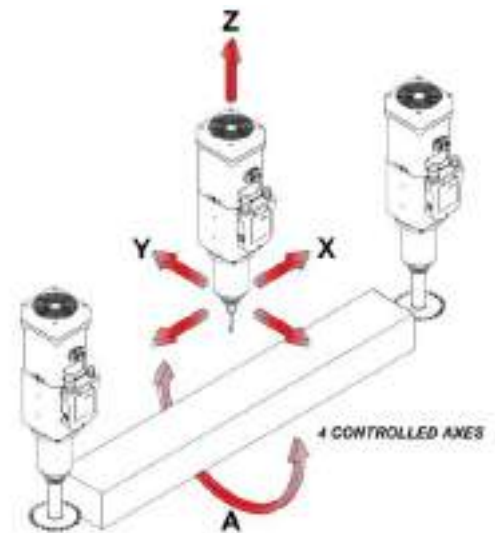

OPTIONS

Automatic vice clamping positioning
 Tooling Station for 4 tools (right side)
 Barcode reader with wire and software
 Tunnel torque L = 500 Top
 Cover complete with windows and two mouths D.100 fume Extraction License
 HICAM license USB for PC (not used simultaneously with the machine)
 Additional license CAD / CAM three-dimensional HICAM 3 with USB
 Connectivity to ORGADATA, FENETECH, OPERA, *.ncw, *.cms, *.ecw, *.ncx

E-3



E-3 / E-4 / E-6 / E-8 ROLLER CONVEYOR

TM-3



TM-3 / TM-4 / TM-6 / TM-8
MANUAL CLAMPING VERSION

TMDG-3



TMDG-3 / TMDG-4 / TMDG-6 / TMDG-8
MANUAL CLAMPING VERSION
Linear encoder and Digital display

TN-3



TN-3 / TN-4 / TN-6 / TN-8
PNEUMATIC CLAMPING VERSION

TNDG-3 / TNDG-4 / TNDG-6 / TNDG-8
PNEUMATIC CLAMPING VERSION
Linear encoder and Digital display

TNDG-3



TM / TN / TMDG / TNDG	3m	4m	6m	8m
Height of table	800-1050mm			
PVC rollers	11	14	20	26
Permissible load	20 Kg /meter			
Positioning accuracy	±0,1mm	±0,2mm	±0,2mm	±0,3mm

AUTOPOS

*The AUTOPOS is a motorized positioning System with linear encoder
Color Touch screen panel
20 lines cutting list*

*AUTOMATIC - CUTTING LIST
SEMIAUTOMATIC
MANUAL*

*Options:
Barcode Scanner
Label Printer*



AUTOPOS + USB

*AUTOPOS with
USB CONNECTION OPTION*

CSV files accepted

Options:

*Barcode Scanner
Label Printer*



PUSHER AUTOPOS

*The PUSHER AUTOPOS is a motorized feeder that can
be attached to any TL or TLG Machine*

*It synchronizes the automation with the clamping and
blade cutting of the Machine*

*The PUSHER AUTOPOS accepts
cutting list and Works in three
modes:*

*AUTOMATIC - CUT LIST
SEMIAUTOMATIC
MANUAL*

*Option:
Pneumatic gripper
Barcode scanner*



*PUSHER AUTOPOS FERRO
Intended for heavy profiles*

C-452-M



C-452-SA

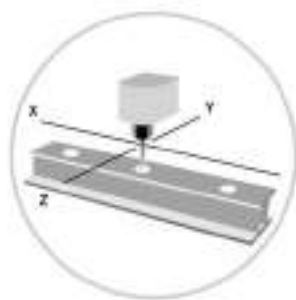

5 ϕ / 8 ϕ

	C-452-M / SA
Desk Size	450 x 230 mm
Longitudinal course	230 mm
Transversal course	110 mm
Vertical displacement	145 mm
Motor	0,5 HP
Cutting speed	9600 rpm
Diameter milling cutter	8 mm
Weight	120 Kg

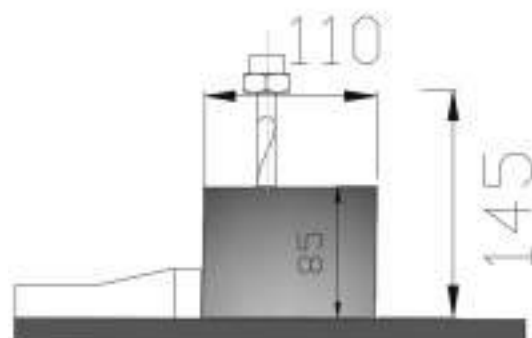

C-500-A / AH



C-500 COPY MILLING MACHINE with two templates installed at the upper side

Easy pattern change by pneumatic operated pin from the working handles

C-500 AH including spindle speed regulation for milling 3mm steel

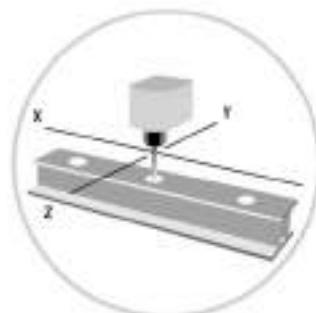

	C-500-A	C-500-AH
Desk Size	500 x 280 mm	500 x 280 mm
Longitudinal course	260 mm	260 mm
Transversal course	140 mm	140 mm
Vertical displacement	150 mm	150 mm
Motor	2 HP	2 HP
Cutting speed	9000 rpm	2000-7000 rpm
Diameter milling cutter	8 mm	8 mm
Weight	150 Kg	150 Kg

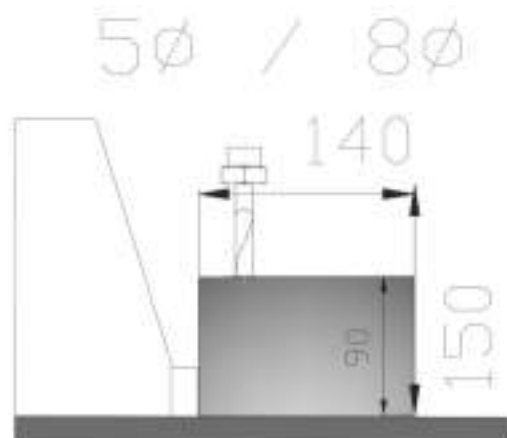

MINI RAFRE-SA



*Portable corner milling Machine
Pneumatic clamping
Pneumatic lubrication*



MINI RAFRE-M



*Portable corner milling Machine
Manual clamping
Manual pumping lubrication*



	MINI RAFRE -M / SA
Motor	2,75 HP
Motor speed	3000 rpm
Motor shaft	27 mm
Milling cutter inner Ø	32 mm
Milling cutters max Ø	120 mm
Course	200 mm
Dimensions	410x400x330 mm
Weight	48 Kg



RAFRE-CR M



RAFRE CR-M
 Manual clamping
 Manual pumping lubrication
 Manual advance of blades

RAFRE-CR SA



RAFRE CR-SA
 Pneumatic clamping
 Pneumatic lubrication
 Manual advance of blades

RAFRE-CR A



RAFRE CR-A
 Pneumatic clamping
 Pneumatic lubrication
 Pneumatic advance of blades

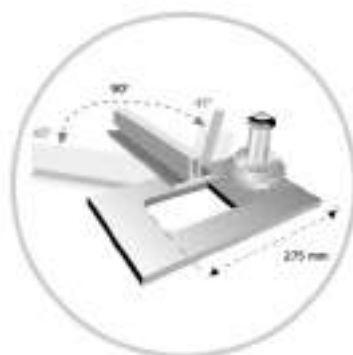

	MINI RAFRE -M / SA / A
Motor	2,75 HP
Motor speed	3000 rpm
Motor shaft	27 mm
Milling cutter inner Ø	32 mm
Milling cutters max Ø	140 mm
Course	275 mm
Dimensions	630x515 mm
Weight	150 Kg



P-3000-G



P-3300-G



P-4000-G



P-8000-G



	P-3000-G	P-3300-G
Max pressure	3000 Kg at 8 ATM	3300 Kg at 8 ATM
Pneumatic pressure	6-8 ATM	6-8 ATM
Light	260 mm	250 mm
Course	35 mm	20-80 mm
Pin speed	23 mm/seg	35 mm/seg
Average air consume x cycle	25 l	35 l
Desk	530 x340 mm	375x230 mm
Height	260 mm	250 mm
Ø of the cylinder	45 mm	45 mm
Weight	75 Kg	60 Kg

	P-4000-G	P-8000-G
Max pressure	4000 Kg at 8 ATM	8000 Kg at 8 ATM
Pneumatic pressure	6-8 ATM	6-8 ATM
Light	250 mm	250 mm
Course	0-50 mm	0-50 mm
Pin speed	32 mm/seg	32 mm/seg
Average air consume x cycle	32 l	32 l
Desk	375 x235 mm	440x260 mm
Ø of the cylinder	45 mm	125 mm
Weight	130 Kg	150 Kg

B-4000-L



The B-4000-L is a Windows assembly table designed to offer a great working surface to where the operator can easily assemble the profiles and accessories

*2 spoolers for rubber
4 storage boxes
6 pneumatic connection points for tools
6 electrical plugs
1 air cleaning gun*

	B-4000-L	B-4000-HV
Dimensions	4000x2000 mm	4000x2000 mm
Weight	162 Kg	230 Kg

B-4000-HV

The B-4000-HV is a Windows assembly table designed to offer a great working surface to where the operator can easily assemble the profiles and accessories working in horizontal or in vertical position

*10 extending modular arms
2 spoolers for rubber
5 storage boxes
6 pneumatic connection points for tools
1 air cleaning gun*



CPP-4100

The CPP-4100 is ideal to move the long six meter profiles from the reception area into the profile storage shelves or to the cutting lines

*4100mm long
1000Kg loading capacity
98 Kg*



CHP-1730

The CHP-1730 is ideal to move the cut profiles from the cutting line to the Assembly area

450Kg load capacity



CV-9

The CV-9 is designed to properly position up to nine finished Windows frames for storage or for transportation to the storage area

*400Kg load capacity
9 x 100mm compartments*



V460 / VORTEX 58/ V570

	V-460 1.5 1200
Motor	2 HP
Sound level	64 dB
Inlet Diameters	1x 100 mm
Suction capacity	1200 m ³ /h
Storage Capacity	100 m ³

	VORTEX 58
Motor	3 HP
Sound level	64 dB
Inlet Diameters	2x 100 mm
Suction capacity	1400 m ³ /h
Storage Capacity	160 m ³



	V-570 3 2500
Motor	4 HP
Sound level	64 Db
Inlet Diameters	2x 160 mm
Suction capacity	2500 m ³ /h
Storage Capacity	160 m ³

Efficient and powerful Vacuum cleaner for Aluminium chips including an integrated container with wheels

VORTEX 600



	VORTEX 600
Motor	4 kW
Suction capacity	4000 m ³ /h

Efficient and powerful Vacuum cleaner for Aluminium chips in continuous operation. Ideally suited to GAA automatic cutting Machines with Automatic Loader of profiles

L-110



	L-110
Max. Crimping force	3500 Kgp
Knives max. stroke	10,5 mm
Bracing clamp stroke	80 mm
Max crimping height	120 mm
Operating crimping regulation	30 to 60 mm
Pneumatic nominal pressure	7 Bar
Weight	300 Kg

C-3/50



	C-3/50
Bending Shafts Ø	50 mm
Central roller max Ø	100-150 mm
Motor	1-1,5 HP
Motor Speed	1500 -3000rpm
Rotations x min	10/20 rpm
Min bending Ø	500 mm
Weight	180 Kg

	60 x 12		60 x 40 x 4 60 x 60 x 3
	80 x 20		Ø 60 x 3 Ø 70 x 2
	40		60 x 60 x 5
	Ø40		
	60 x 50 x 5		60 x 40 x 5



TRONZADORAS MG,S.A.
Pol.Ind. Font de la Parera
La Roca del Valles - 08430
Barcelona - Spain
T.+34 938424160
info@tronzadorasmg.com
www.tronzadorasmg.com

Tronzadoras MG reserves the right to perform any modification in this catalogue for technical or commercial purposes

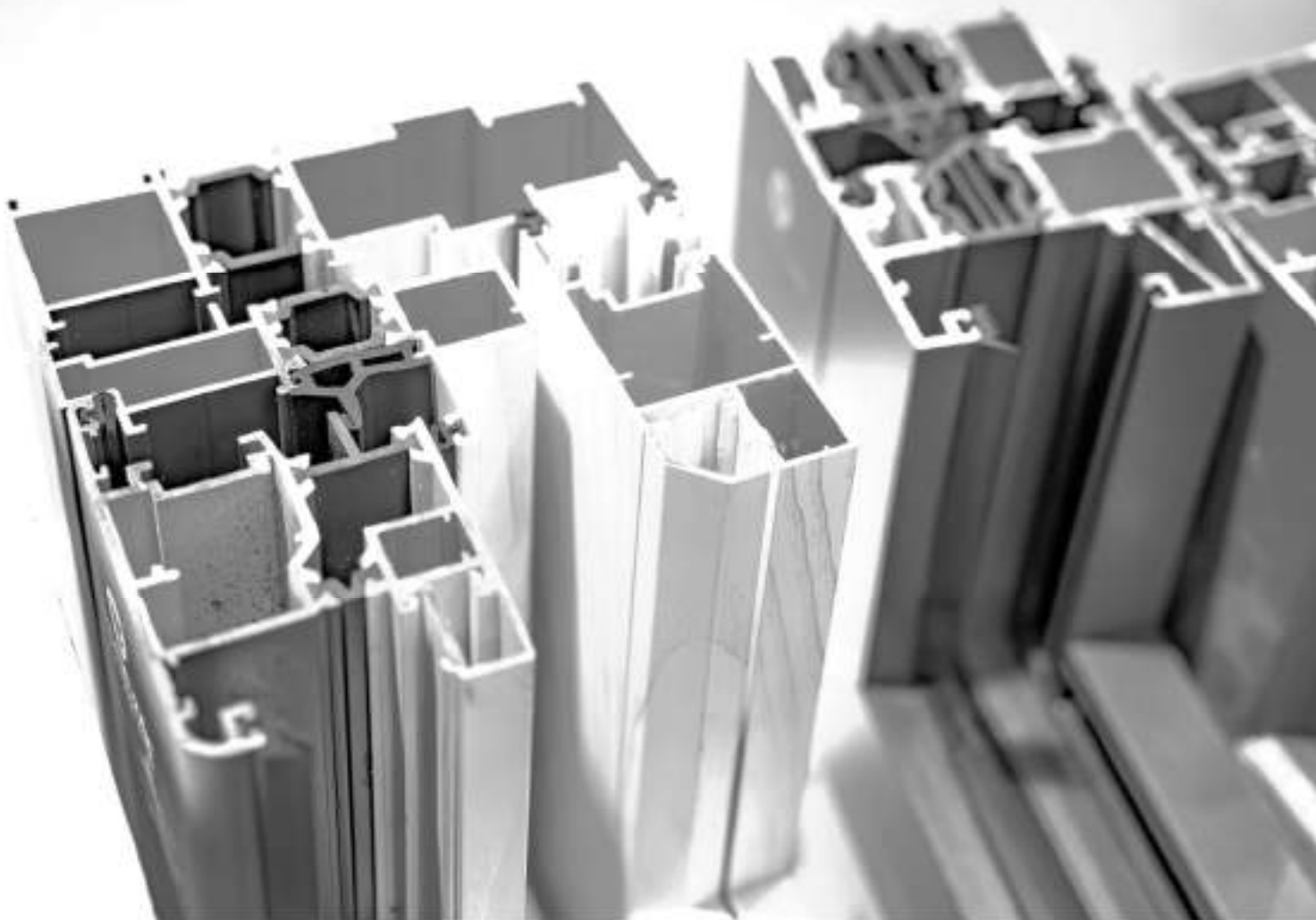

MADE
SPAIN