

SUCCESS AND QUALITY GUARANTEE

VARO, since 1979, has been one of the main European brands for design and supply of machines for the transformation of metal wire.

The company, founded and led by the Rota family, has established itself on the markets international thanks to the very high quality and reliability of its machines. VARO, born in a territory traditionally linked to processing and transformation of metal wire, has grown by truly focusing on the customer's needs. VARO, during the years, has been able to earn, in the eyes of sector operators, the role of partner reliable and trustworthy.

By virtue of the presence of an advanced internal mechanical department equipped with the most recent technologies in the field of machine tools, VARO is able to study and implement any possible equipment ensuring the customer maximum adherence to own project needs.



Wire processing machineries

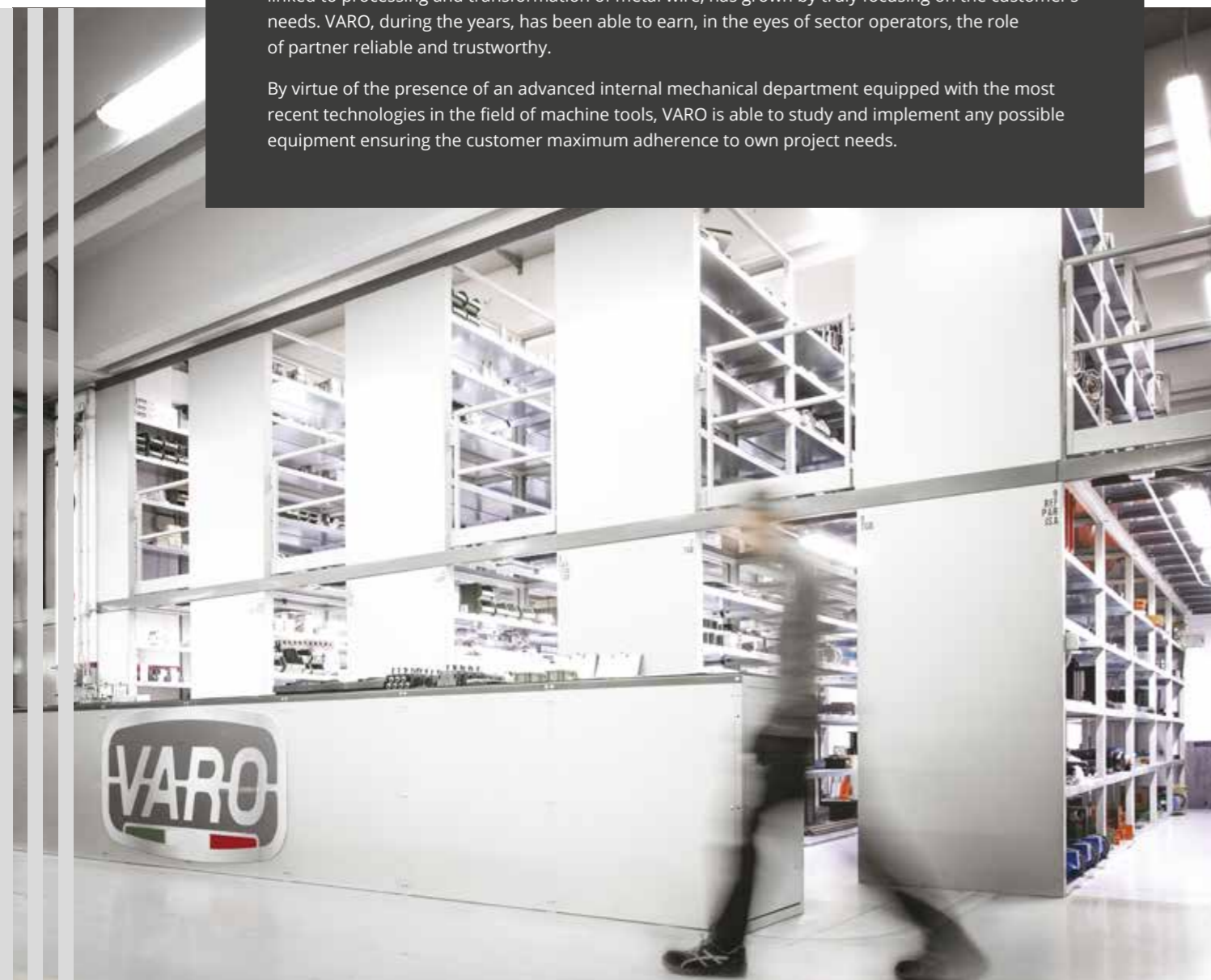

VARO SRL

Via Roma, 87
23868 Valmadrera (LC)

+39 0341 580164
info@varo.it

Wire processing machineries

VARO.IT

MAS2

Automatic machine for the production of welded rings

- WELDING
- FORMING**
- CUTTING
- ACCESSORIES
- SPECIAL LINES
- ROBOTIZED ISLE



RING MACHINE

MAS 2 the automatic plant for the production of welded rings is one of the flagship products of the **VARO** offer. The high production capacity, the remarkable simplicity of use and maintenance, are the main features of **MAS 2**.

The wide range of workable wire diameters and the speed of making dimensional changes make this machine extremely adaptable and, at the same time, suitable to meet medium / high production needs.

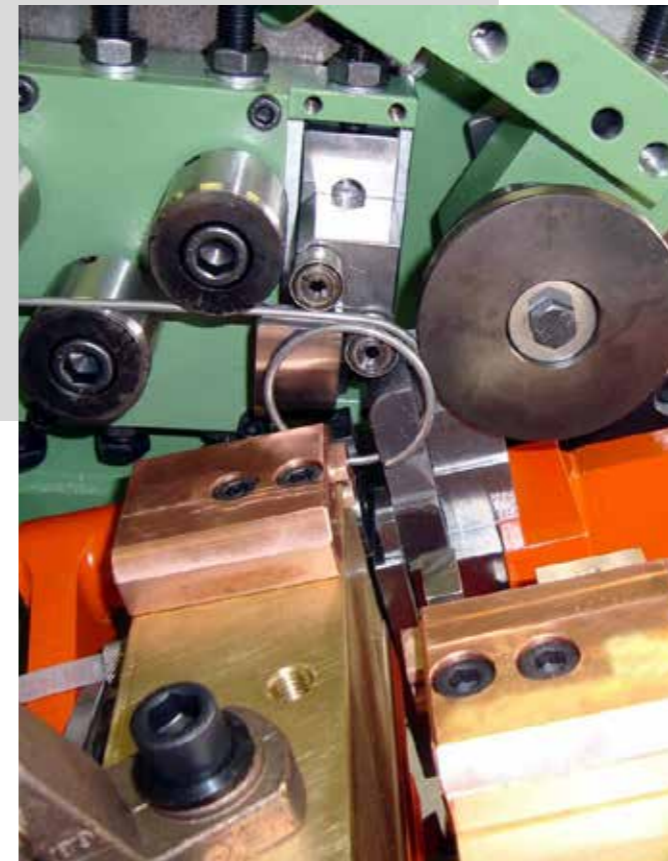

TECHNICAL FEATURES

Wire diameter	1,5 to 10,0 mm
Inner diameter of the welded ring	35 - 50 mm
Internal diameter but of the non-welded ring	25 mm
Internal diameter max of the ring - without extension	600 mm
Internal diameter max of the ring - with extension arm	1200 mm
Calandra bending heads	Calandra
Welding Machine Accessories	Welding (for frame welding)
	Stamping presses
Transformer welding power	30 kVA
Cutting unit	Hydraulic
Straightening unit	Static rollers
Reel	Motorized reel, capacity 15 Qt

DIRECT COIL FEEDING

Thanks to the extremely precise static straightening system with opposed rollers as well as the advancement system equipped with an encoder, **MAS 2** is directly fed from the coil allowing the machine to work without the presence of an operator on the machine.

WELDING GROUP AND MORE

Butt welding is performed by a unit designed & manufactured by **VARO** using the most advanced and reliable technologies available on the market.

MAS 2 is powered by a 30 Kva power unit and equipped with related control and handling devices for the produced item.

In addition, it can be equipped with independent units for special processing, such as molding presses to create star, "V" or "U" shapes, etc.

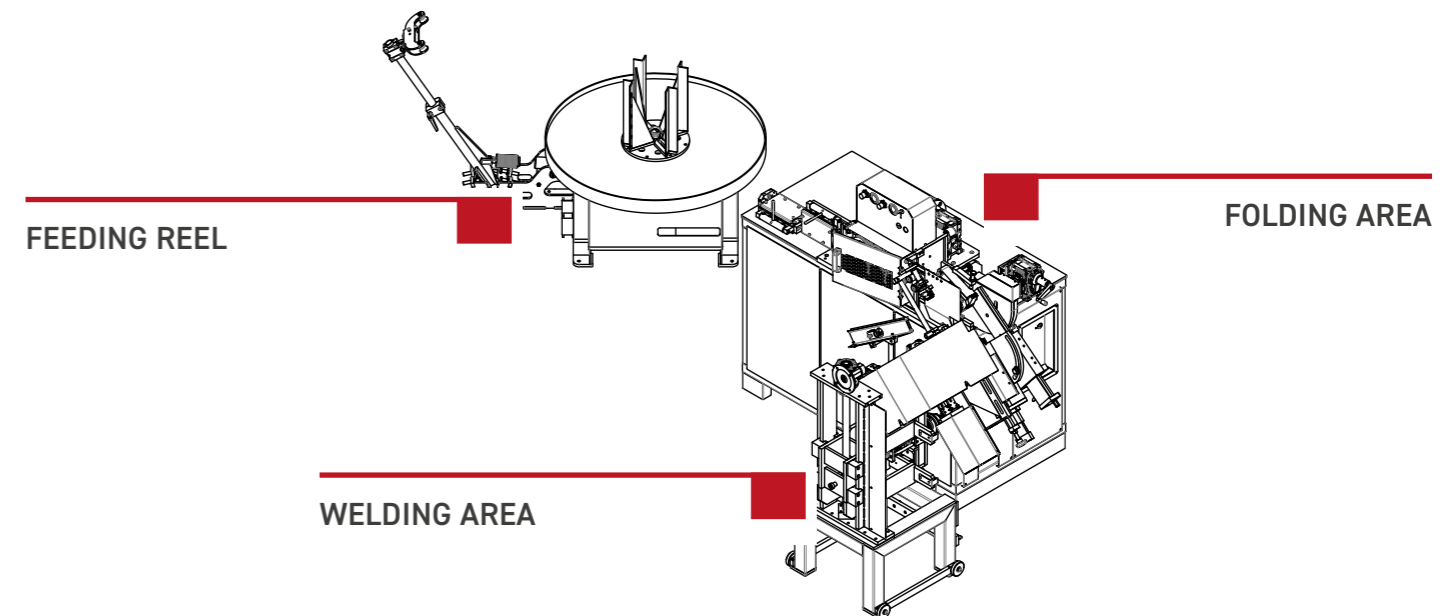

CONSTANT MONITORING



In the 4.0 set-up VARO is able to provide all the necessary and relevant information about production trends and about the functionality of the machine itself. The information collected allows you to have a clear view of productivity, **also available remotely and from smartphones thanks to MyVARO APP:**

- Alarm history
- Recipe history
- Production history

PRODUCTS SHEETS



For more information scan the QR Code.

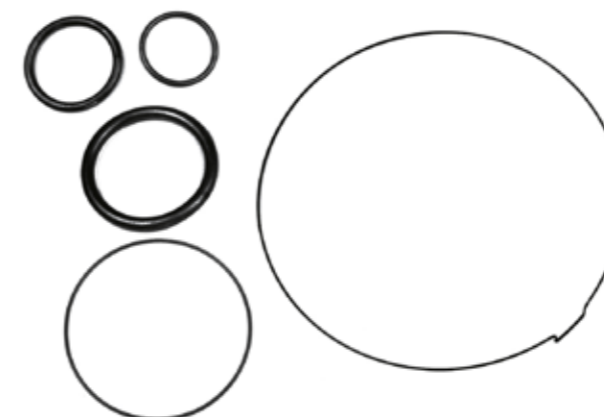

Thanks to the excellent quality level achieved in recent years, VARO has been able to offer itself in many markets, both European and non-European, presenting the MAS-2 machine as a worldwide business card.