

PRIMA INSERTER

Pressa per inserti autoaggancianti
Press for self-clinching fasteners



Divisione Macchine

La potenza in sicurezza *Power in safety*



Sicurezza ●
Safety

Versatilità ●
Flexibility

Alta qualità ○
High quality

○ *International patent*



PRIMA INSERTER

 **PRIMA INSERTER** è una pressa per inserti autoaggancianti, piccola nelle dimensioni, ma grande nelle prestazioni. Costruita con il meglio della componentistica mondiale per essere affidabile nel tempo. La sua versatilità, facilità d'uso e di manutenzione la rendono indispensabile per risolvere in sicurezza tutti i problemi legati all'utilizzo di inserti autoaggancianti.

Prima per VERSATILITÀ

La compattezza e la geometria della struttura consentono di posizionare inserti con forze variabili fino a 6.000 Kg. su una vasta tipologia di sagome.

Prima per SICUREZZA

L'utilizzo di carrelli mobili consente di ridurre la distanza tra matrice e punzone ai valori prescritti dalle normative di sicurezza.

Prima per rapporto QUALITÀ-Prezzo

Caratteristica che siamo certi apprezzerete già dal primo incontro con PRIMA INSERTER.



PRIMA means "FIRST":

First in FLEXIBILITY

Compactness and geometry of the structure allow to install inserts with a force that goes up to 6,000 kg for a vast numbers/types of shapes.

First in SAFETY

Moving saddles reduce the distance between the anvil and the punch within the values of safety.

First in QUALITY to PRICE rate

This is a feature you will appreciate at the very first encounter with PRIMA INSERTER.

PRIMA INSERTER

 **PRIMA INSERTER**, our press for self-clinching fasteners, is small in size but great in its performance. It is built with the very best components the world market offers, in order to guarantee a long lasting reliability. Simple to use and to maintain, and extremely flexible in the number of works it can do, it becomes indispensable in safely solving the problems one may encounter when utilising self-clinching fasteners.

Accessorio N°2

Accessory N°2

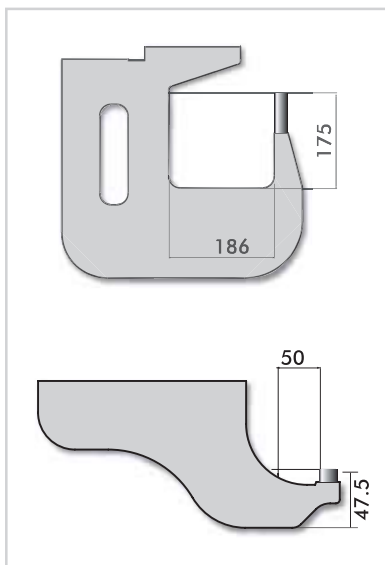

Sagome intercambiabili - Interchangeable frames



 L'accessorio n.2 con le sue sagome intercambiabili, realizzabili anche su disegno del cliente, permette di applicare inserti in scatolati e laminati metallici dalle forme piu` varie.

 Accessory No.2, with its changeable frames that can be made also per your drawings, enables you to insert fasteners in box-shaped pieces and in the most varied shapes of metal sheets.

Accessorio N°1

Accessory N°1



 L'accessorio n.1 permette di applicare inserti in scatolati e laminati metallici la cui forma ricorda una "C".

 Accessory No. 1 enables you to insert fasteners in "C"- like pieces.

Misure e ingombri - Dimension

Prima inserter	Senza basamento Without Base	Con basamento With base
Peso - Weight	50 kg - (110 lbs)	93 Kg - (204,6 lbs)
Altezza - Height	311 mm - (12,24")	1295 mm - (50,98")
Profondità - Depth	516 mm - (20,31")	730 mm - (28,74")
Larghezza - Width	250 mm - (9,84")	380 mm - (14,96")

Caratteristiche tecniche - Technical data

Azionamento - Drive	aria compressa - compressed air 6 - 10 bar.
Alimentazione - Power	220 v / 100 w - (opt. 110 v / 100 w single phase)
Forza di compressione - Force range	280kg - 6.000 kg - (600 lbs to 14.000 lbs)
Massimo spessore - MAX. sheet thickness	3 mm - (0,12")

Prima Inserter
(mm)

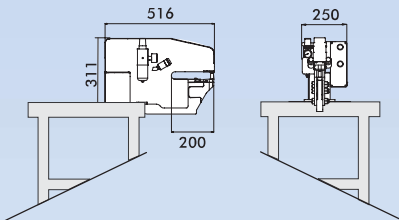

Accessorio n° 2 - Accessory n° 2
(mm)

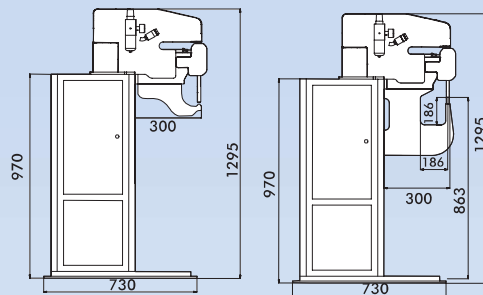

Accessorio n°1 - Accessory n°1
(mm)

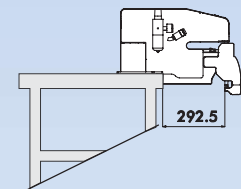

Con accessorio n. 2 basamento obbligatorio
In order to utilize Accessory No. 2, it is mandatory to install the press on its stand.

OPTIONALS

Basamento fisso (mm)
Fixed Stand

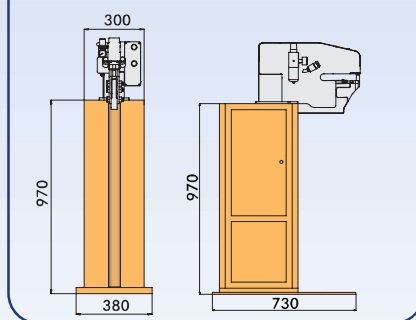

Lampada
Lamp

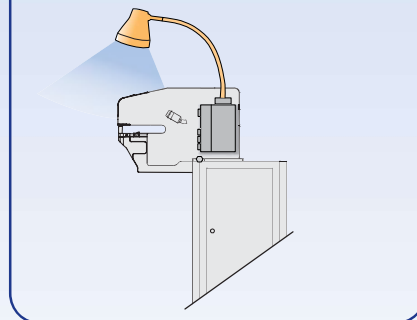

Basamento sollevabile (mm)
Risable Stand

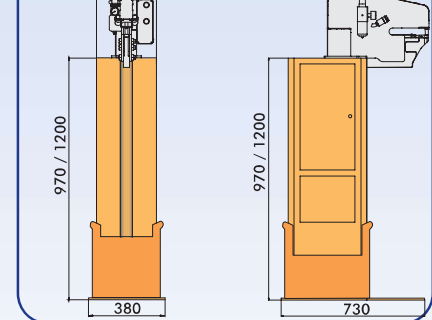

Distributed by: