

# SERIE V-VP

## PROFESSIONAL

- Manual feed (serie V.32 and V.40) - automatic feed (VP.40)
- V-belt drive (V.32), mechanical variator of conical pulleys (V.40 and VP.40)
- Displaceable table and fixed headstock



## Standard equipment

- Adjustable depth end
- Tool ejector
- Belt cover with stop micro
- Emergency push button
- Turning sense selector
- Electrical equipment at low voltage
- Drill guard with stop micro
- CE norms



## Extra Equipment

- 20010** Lighting equipment
- 91118** Coolant equipment
- 20082** Rotating table (serie V.32)
- 30084** Rotating and tilting table (series V.40, VP.40)
- 20087** Reversible rotating table with vice (series V.40, VP.40)
- 20042** Tapping system IR/RS

# Characteristics

	V.32	V.40	VP.40
DRILLING CAPACITY IN STEEL OF 70 Kg. (mm)	32	40	40
TAPPING CAPACITY IN STEEL OF 70 Kg.	M24	M32	M32
TRANSMISSION	V-BELT	MECHANICAL VARIATOR OF CONICAL PULLEYS	
SPEED NUMBER AND RANGE 50 HZ.	245-355-490-710-835- 1240-1670-2000-2480- 4000 rpm.		Variable 80 - 1170 rpm.
FEED	MANUAL	MANUAL	AUTOMATIC
NUMBER AND FEED NUMBER	-	-	(2) 0,10-0,20
CLUTCH	-	-	MECÁNICO
MAIN MOTOR POWER - 750/1500 rpm.	1,8/3,2 HP	1,8/3,2 HP	1,8/3,2 HP
SPINDLE CONE	MT3	MT4	MT4
SPINDLE STROKE	120 mm	150 mm	190 mm
DISTANCE SPINDLE-COLUMN	250 mm	300 mm	
DISTANCE SPINDLE-TABLE	Min. 85 mm/ Max. 635 mm	Min. 150 / Max. 950 mm	
DISTANCE SPINDLE-BASE	1195 mm	1310 mm	
COLUMN DIAMETER	Ø100 mm	Ø125 mm	
DIMENSIONS OF THE TABLE (WITH 2 T SLOTS)	270x300 mm	400x420 mm	
DIMENSIONS OF THE BASE WITHOUT T SLOTS (WITHOUT COOLANT)	600x380 mm	400x655 mm	
DIMENSIONS OF THE BASE WITH 2 T SLOTS (WITH COOLANT)	665x400 mm	492x655 mm	
WEIGHT: NET / GROSS Kg.	260 / 320 Kg.	260 / 320 Kg.	
PACKAGING DIMENSIONS AND VOLUME	2110x570x800 mm - 0,97 m <sup>3</sup>	2080x630x1110 mm - 1,45 m <sup>3</sup>	

# Dimensions

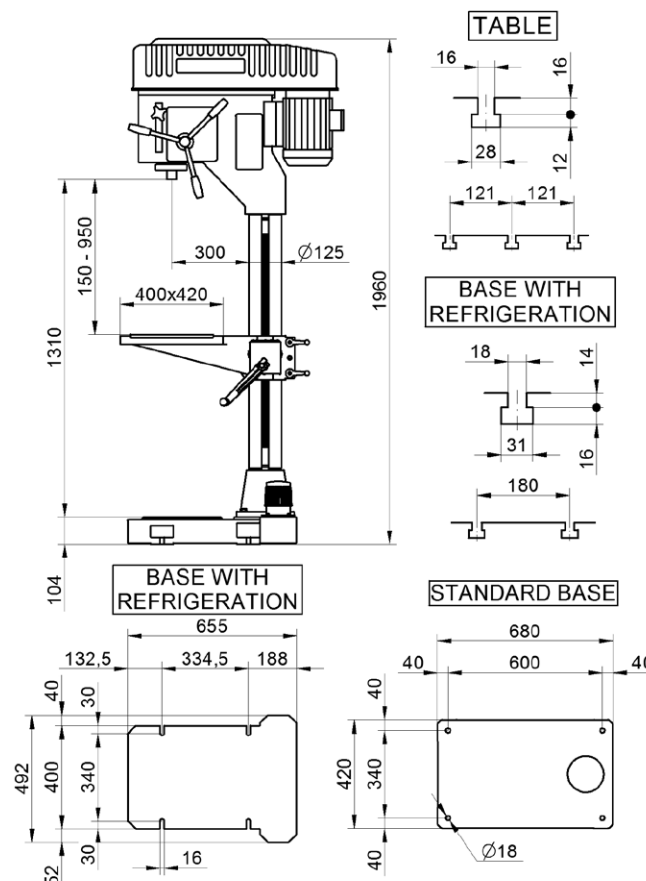

V.40/VP.40