

ALUMINUM 90° AUTOMATIC CUTTING / & DRILLING

GAA-350 CNC

✓Optional: drilling unit



*Picture corresponds to GAA-350-90 TR12 CNC sawing machine with drilling/tapping unit

EXAMPLE:



	GAA-350-90 / CNC
Blade Dimensions	350 Ø mm
Motor	2,5 HP (1,8Kw)
Motor speed	3000 rpm
Feeder lenght	300 mm / 700mm CNC
Cutting degrees	90°
Weight of the machine	260 Kg / 320 Kg
Dimensions	1400x850x970 / 1500x1200x970

GAA-350-90



✓CNC version with servo motor and touch screen panel
✓PRODUCT LIBRARY + CUTTING LIST

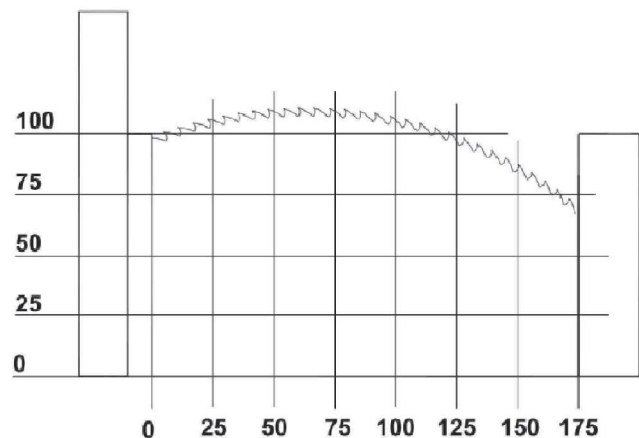

ALUMINUM 90° AUTOMATIC CUTTING / & DRILLING

GAA-500-90

✓Optional: drilling unit

✓CNC version with servo motor and touch screen panel

✓PRODUCT LIBRARY + CUTTING LIST

GAA-500 CNC



	GAA-500-90 /CNC
<i>Blade Dimensions</i>	500 Ø mm
<i>Motor</i>	4 HP
<i>Motor speed</i>	40/80 mt/min
<i>Feeder lenght</i>	500 mm / 700 mm
<i>Cutting degrees</i>	90°
<i>Weight of the machine</i>	450 kg / 520 Kg
<i>Dimensions</i>	1400x850x1700 / 1950x1200x970

*GAA-500-90 CNC + TR20

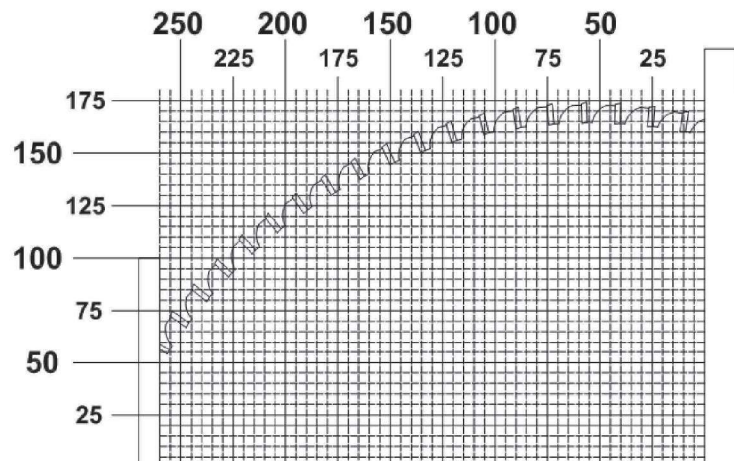

ALUMINUM 90° AUTOMATIC CUTTING / & DRILLING

GAA-600-90 CNC GAA-650-90 CNC



✓Optional: drilling units

✓CNC version with servo motor and touch screen panel
✓PRODUCT LIBRARY + CUTTING LIST

	GAA-600-90 / CNC
<i>Blade Dimensions</i>	600 Ø mm
<i>Motor</i>	5,5 HP (4 Kw)
<i>Motor speed</i>	3000 rpm
<i>Feeder lenght</i>	500 mm /700mm servo
<i>Cutting degrees</i>	90°
<i>Weight of the machine</i>	675 kg
<i>Dimensions</i>	1500x950x1850 mm

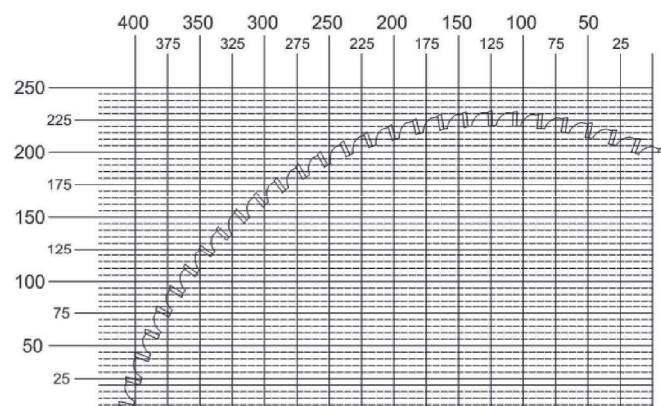

	GAA-650-90 / CNC
<i>Blade Dimensions</i>	650 Ø mm
<i>Motor</i>	7,5 HP (5,5 Kw)
<i>Motor speed</i>	3000 rpm
<i>Feeder lenght</i>	500 mm /700mm servo
<i>Cutting degrees</i>	90°
<i>Weight of the machine</i>	675 kg
<i>Dimensions</i>	1500x950x1850 mm

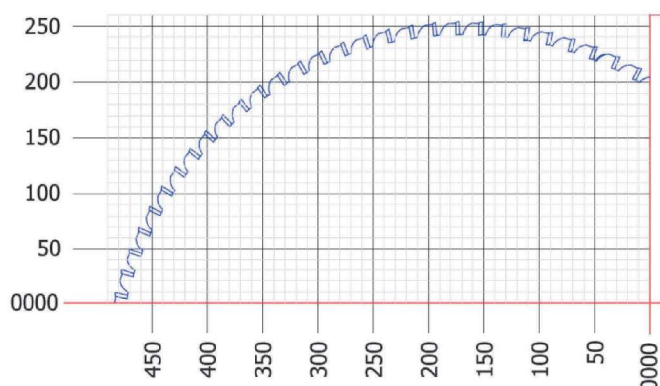

ALUMINUM 90° AUTOMATIC CUTTING / & DRILLING

GAA CNC / SPECIAL

✓GAA CNC BASED MODELS
WITH DRILLING & TAPING
UNITS

✓VERTICAL / HORIZONTAL /
FRONTAL DRILLING UNITS

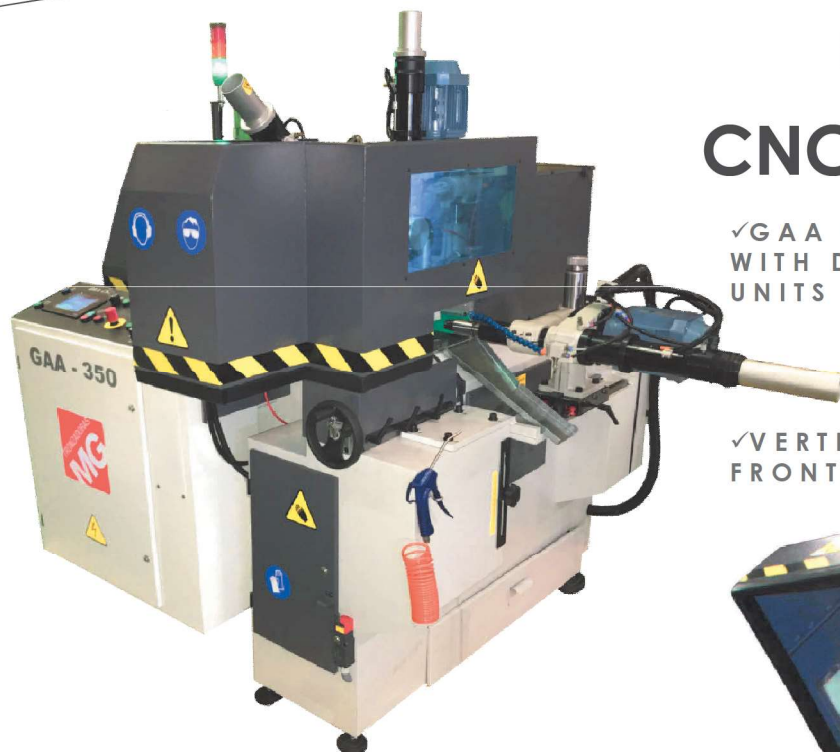

✓Examples:

