

FOR MAKERS. SINCE 1957.



ECKOLD

**SCHIENENFAHRZEUG- UND
WAGGONBAU**

TRAIN, RAILWAY AND CARRIAGES

BLECHUMFORMUNG SHEET METAL FORMING



ECKOLD Kraftformer sind im Einsatz beim Formen von Profilen und Verkleidungsblechen für den japanischen Shinkansen Express und für viele andere Anwendungen bei anderen Kunden.

Ob Profile, Radien oder Kurven, mit der ECKOLD Umformtechnologie bringen Sie Aluminium, Stahl und Edelstahl in die gewünschte Form. So kommt unser Know-How auch beim deutschen ICE 3 zum Einsatz.

ECKOLD Kraftformer machines used to form profiles and skin sheets for the train head of the Japanese Shinkansen trains and for many other applications at other customers.

No matter whether you have to bend profiles, radii or curves, the ECKOLD Forming Technique easily brings aluminium, steel or even stainless steel into the desired shape. This know-how helped building the German ICE 3.



**MIT HIGH-SPEED
ÜBER DIE SCHIENE...**

**HIGH SPEED ON
TRACK...**

TYPISCHE AUFGABEN TYPICAL JOBS

- VERSTÄRKUNGSPROFIL FÜR DIE FRONTHAUBE.
- REINFORCING STRIP FOR THE FRONT OPENING HOOD.



- ECKELEMENT FÜR DAS DACH EINES TRIEBWAGENS.
- CORNER SEGMENT FOR THE ROOF OF A RAILCAR.



- SONDERPROFILE FÜR FENSTER-RAHMEN ANPASSEN UND RICHTEN.
- ADJUSTING AND CORRECTING SPECIAL WINDOW PROFILES.



- BLECHE MASSGENAU HERSTELLEN.
- FORMING SHEETS WITH HIGH PRECISION.

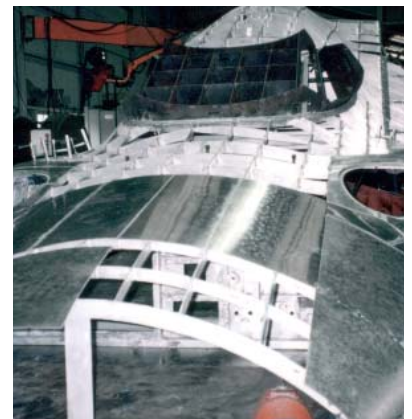

ECKOLD

KRAFTFORMER HANDFORMER MULTIFORMER

Universell einsetzbare Maschinen zur spanlosen Kaltformung von Blechen und Profilen.
Universal machines for chipless coldforming of sheet metal and profile sections.

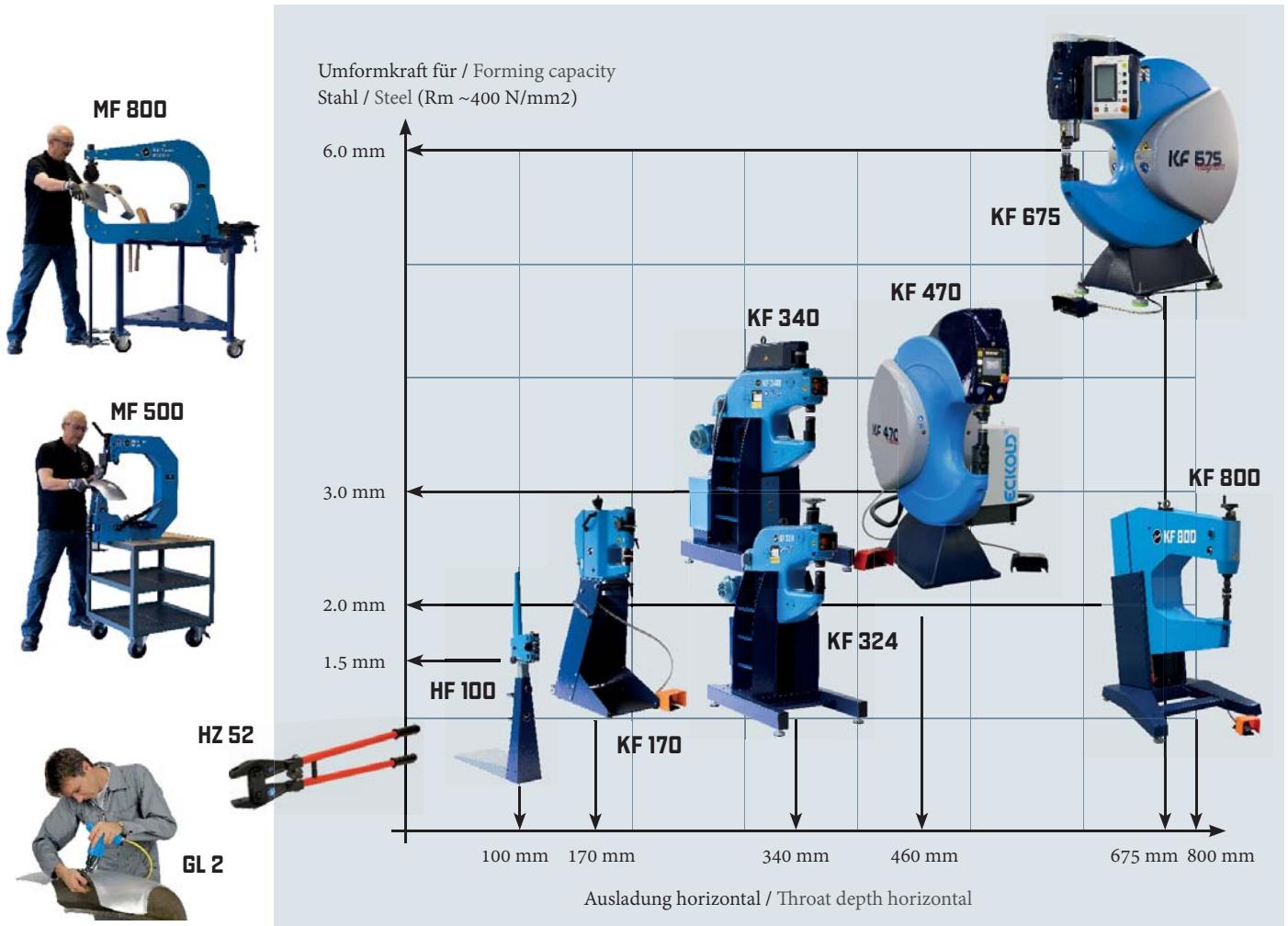

© ECKOLD AG / BP Schienenfahrzeug und Waggonbau De_En 2019-08

ECKOLD

UMFORMWERKZEUGE FORMING TOOLS

Werkzeuge zum Stauchen, Strecken, Wölben, Glätten, Spannen, Richten, Bördeln, Schweißen, Ausschneiden, Lochstanzen und Abkanten.

Tools for shrinking, stretching, doming, planishing, flattening, straightening, flanging, swaging, notching, punching and edging.

