

FOR MAKERS. SINCE 1957.



**ECKOLD**

**FLUGZEUGBAU UND WARTUNG**  
**AIRCRAFT PRODUCTION AND**  
**MAINTENANCE**

# BLECHUMFORMUNG SHEET METAL FORMING



Stauhen und Strecken sind unverzichtbare Anwendungen im Flugzeugbau, denn damit werden viele Arten von gepressten Teilen korrigiert oder angepasst. Die speziellen Maschinen und Werkzeuge von ECKOLD bieten eine hoch effiziente Lösung zur präzisen Anpassung von individuellen Teilen.

Shrinking and stretching are indispensable operations in aircraft manufacturing, mainly for correcting and adjusting of pressed parts of all sorts. The special machines and tooling of ECKOLD offer a highly efficient solution to assure precise fitting together of the individual parts.



## **TECHNIK IN HÖCHSTER QUALITÄT:**

- **IM FLUGZEUGBAU**
- **IN DER FLUGZEUGWARTUNG**

## **TAKE OFF WITH ECKOLD:**

- **IN AIRCRAFT PRODUCTION**
- **IN AIRCRAFT MAINTENANCE**

## TYPISCHE AUFGABEN TYPICAL JOBS

- DIE FEINFÜHLIGE DRUCKREGULIERUNG DER ECKOLD MASCHINEN ERLAUBT DIE FERTIGUNG ODER DAS RICHTEN VON TEILSTÜCKEN UND KOMPLETTEN WINKELPROFILIEN SOWIE DAS RICHTEN VON PRESSTEILEN.
- SENSITIVE PRESSURE ADJUSTMENT OF THE ECKOLD MACHINES IS THE IDEAL FEATURE FOR CORRECTING AND ADJUSTING OF PROFILE SECTIONS AND PRESSED PARTS.



- KRAFTFORMER WERDEN AUCH IM REPARATUR- UND UNTERHALTSBEREICH EINGESETZT (MRO).
- KRAFTFORMER MACHINES ARE WIDELY USED IN THE MRO WORKSHOPS AS WELL.



- RICHT- UND ANPASSUNGSARBEIT VON EINEM PRESSTEIL IM RUMPFBEREICH DES AIRBUS A340.
- CORRECTING AND ADJUSTING OF A PRESSED PART OF THE FUSELAGE SECTION OF AN AIRBUS A340.



- RICHTEN EINES ABDECKUNGSTEILES IM BODENBEREICH FÜR DEN AIRBUS A380 MIT DEM KRAFTFORMER.
- CORRECTING JOB WITH ECKOLD FORMING MACHINE OF A LOWER COVERING PART OF OF THE FLOOR SECTION FOR THE AIRBUS A380.



# ECKOLD

## KRAFTFORMER HANDFORMER MULTIFORMER

Universell einsetzbare Maschinen zur spanlosen Kaltformung von Blechen und Profilen.  
Universal machines for chipless coldforming of sheet metal and profile sections.

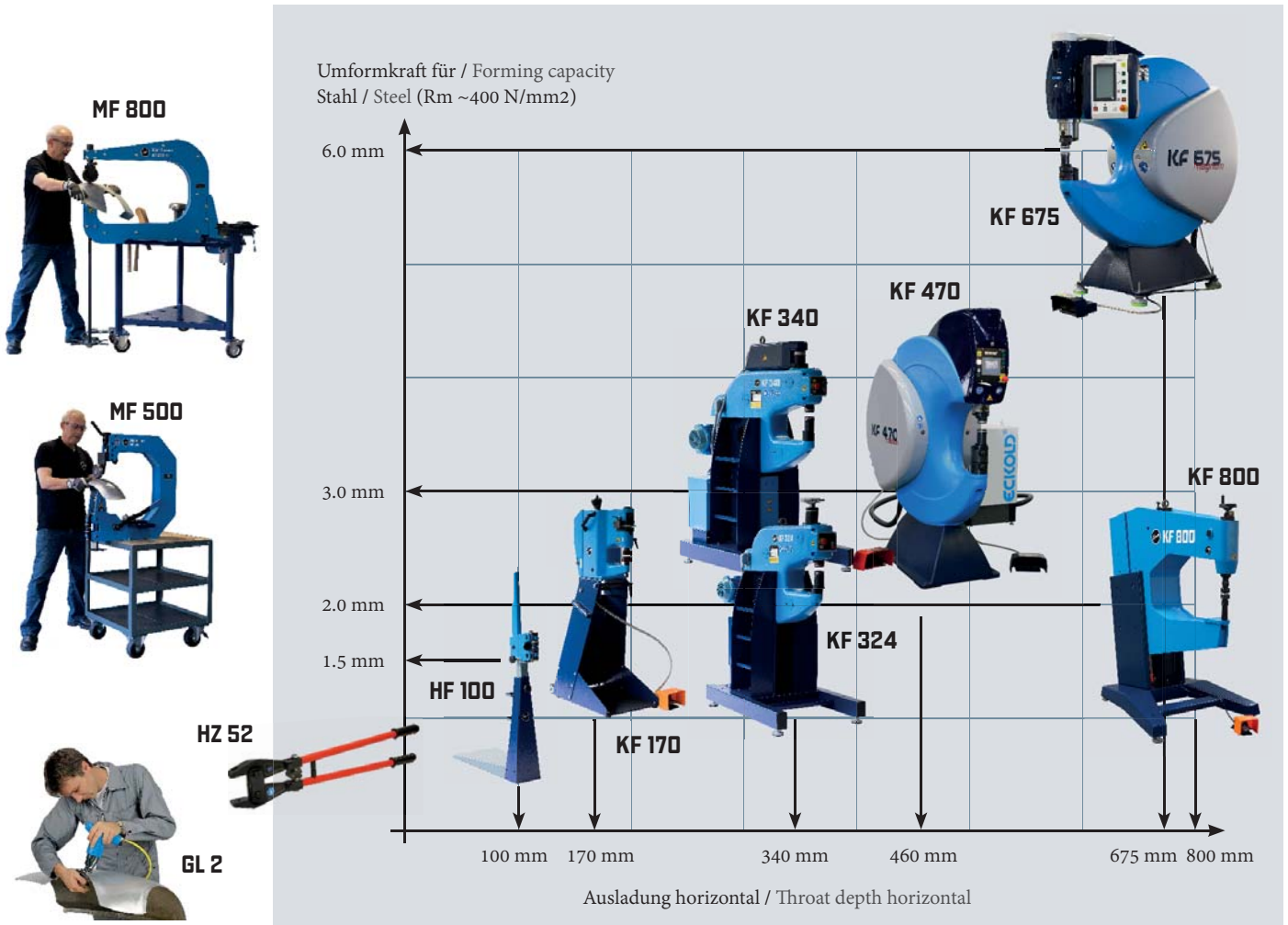

© ECKOLD AG / BP Flugzeugbau und Wartung De\_Ein 2019-08

# ECKOLD

## UMFORMWERKZEUGE FORMING TOOLS

Werkzeuge zum Stauchen, Strecken, Wölben, Glätten, Spannen, Richten, Bördeln, Schweißen, Ausschneiden, Lochstanzen und Abkanten.

Tools for shrinking, stretching, doming, planishing, flattening, straightening, flanging, swaging, notching, punching and edging.

